

DESIGN OF VARIOUS MULTIBAND SLOT ANTENNAS

A MASTER'S THESIS

IN ELECTRICAL & ELECTRONICS ENGINEERING DEPARTMENT

ATILIM UNIVERSITY

By

WAFI MUSTAFA LAMIN MAHMOUD

August 2017

DESIGN OF VARIOUS MULTIBAND SLOT ANTENNAS

A THESIS SUBMITTED TO

THE GRADUATE SCHOOL OF NATURAL AND APPLIED SCIENCES

OF

ATILIM UNIVERSITY

BY

WAFI MUSTAFA LAMIN MAHMOUD

**IN PARTIAL FULFILLMENT OF THE REQUIREMENTS FOR THE
DEGREE OF**

MASTER OF SCIENCES

IN

**THE DEPARTMENT OF ELECTRICAL AND ELECTRONICS
ENGINEERING**

August 2017

Approval of the graduate school of Natural and Applied Sciences, Atilim University.

Prof. Dr. Ali Kara

Director

I certify that this thesis satisfies all the requirements as a thesis for the degree of Master of Science.

Asst. Prof. Dr. Kemal Efe Eseller

Head of Department

This is to certify that we have read the thesis “Design Of Various Multiband Slot Antennas” submitted by “WAFa MUSTAFA LAMIN MAHMOUD” and that in our opinion it is fully adequate, in scope and quality, as a thesis for the degree of Master of Science.

Prof. Dr. Elif Aydin

Supervisor

Examining Committee Members

Asst. Prof. Dr. Kemal Efe Eseller

Prof. Dr. Elif Aydin

Prof. Dr. Ali Kara

Assoc. Prof. Dr. Nursel Akcam

Asst. Prof. Dr. Hakan Tora

Date: 25/08/2017

I declare and guarantee that all data, knowledge and information in this document have been obtained, processed and presented in accordance with academic rules and ethical conduct. Based on these rules and conduct, I have fully cited and referenced all material and results that are not original to this work.

WAFI MUSTAFA LAMIN MAHMOUD

ABSTRACT

Design of various multiband slot antennas

WAFI MUSTAFA LAMIN MAHMOUD

M.S., Electrical & Electronics Engineering

Department

Supervisor: Prof. Dr. Elif AYDIN

August 2017, 49 pages

In these days, microstrip antennas cover a wide range of application in various areas, such as internet services, mobile communication, and satellite navigation. Microstrip antenna consists of two metal layers and a substrate. In the two metal layers, the top layer is called the patch and the bottom layer is called the ground. Between the patch and the ground there is the substrate layer which has a certain dielectric constant and thickness. The goal of this work is presenting a way of getting multi-band antennas for Wi-Fi devices and Wireless Communication System. These bands of frequency cover the standard IEEE 802.11b/g (2.4-2.485GHz) and IEEE 802.11a (5.15-5.35GHz) for WLAN applications and 2.5 GHz (2.5-2.69GHz), 3.5 GHz (3.3-3.8GHz) and 5 GHz (5.25-5.85GHz) for Wi-MAX applications. We have used two different designs using program of software HFSS that has been used for simulation process. The multiband slot antennas have been simulated and manufactured by using two types of feeds. Firstly, the design of the antenna used the microstrip feed line and then we used the coplanar (CPW-Fed). Multi-band microstrip antennas were designed and simulated in terms of the return loss (S_{11}) and the gain. These designs were fabricated and their return loss were measured and compared with the simulation results.

Keywords: Microstrip antenna, slot antenna, and multiband antenna.

ÖZ

Çokbantlı Çeşitli Yarık Anten Tasarımı

WAFI MUSTAFI LAMIN MAHMOUD

Yüksek Lisans,

Elektrik Elektronik Mühendisliği Bölümü

Tez Yöneticisi: Prof. Dr. Elif AYDIN

Ağustos 2017, 49 sayfa

Bu günlerde, mikro şerit antenler internet hizmetleri, mobil iletişim ve uydu navigasyonu gibi çeşitli alanlarda geniş bir uygulama yelpazesi bulunmaktadır. Mikroşerit anten iki metal tabakadan ve bir alt tabakadan oluşur. İki metal tabakadan üst katman yama, alt katman isetopraktır. Yama ile toprak arasında belli bir dielektrik sabitine ve kalınlığa sahip alt katman tabakası bulunur. Bu çalışmanın amacı, Wi-Fi cihazları ve Kablosuz İletişim Sistemi için çok bantlı antenler tasarlanmasının yolunu sunmaktır. Bu frekans bantları, WLAN uygulamaları için standart IEEE 802.11b / g (2.4-2.485GHz) ve IEEE 802.11a (5.15- 5.35GHz) ile 2.5 GHz (2.5-2.69GHz) ve 3.5 GHz (3.3-3.8GHz) ve Wi-MAX uygulamaları için 5 GHz (5.25-5.85GHz) bantlarını kapsamaktadır. Benzetim için HFSS yazılımını kullanarak iki farklı tasarım yaptık. Çok bantlı yuvalı antenler, iki tür besleme kullanılarak benzetimi yapılmış ve üretilmiştir. Öncelikle, anten tasarımında mikro şerit besleme hattını ve ardından eş düzlemlili (CPW-Besleme) kullandık. Çok bantlı mikro şerit antenler, geri dönüş kaybı (S_{11}) ve kazanç açısından tasarlandı ve benzetimi yapıldı. Bu tasarımlar imal edildi ve dönüş kayıpları ölçüldü ve benzetim sonuçları ile karşılaştırıldı.

Anahtar Kelimeler: Anten, mikroşerit anten, yarık anten, çokbantlı anten.

To my husband and all my family without whom none of my success would be possible.

ACKNOWLEDGMENTS

All praise is to Allah for blessing. I would like to express my profound sense of thank to my supervisor Prof. Dr. Elif AYDIN for her help and guidance during this study. A special thanks to my family and my friends.

I would like to address to the staff of the embassy of Libya, who supported me to complete this thesis.

Last but by no means least; I would like to thank warmly my husband, for his support in all events. I would also like to thank him for his understanding and patience during all time of my study.

CONTENTS

ABSTRACT.....	i
ÖZ.....	ii
DEDICATION.....	iii
ACKNOWLEDGMENTS.....	iv
CONTENTS.....	v
LIST OF TABLES.....	vii
LIST OF FIGURES.....	viii
CHAPTER ONE.....	1
INTRODUCTION.....	1
CHAPTER TWO.....	3
MICROSTRIP ANTENNA.....	3
2.1A HISTORY AND INFORMATION OF MICROSTRIP ANTENNA.....	3
2.2 CHARACTERISTICS OF MICROSTRIP ANTENNA.....	4
2.2.1 Advantages.....	5
2.2.2 Disadvantages.....	5
2.3 APPLICATIONS OF MICROSTRIP ANTENNA.....	6
2.4 MICROSTRIP FEED.....	7
2.5 METHODS OF ANALYSIS.....	9
2.6 RECTANGULAR PATCH.....	9
2.6.1 Transmission Line Model.....	9
2.6.1.1 Fringing Effects.....	10
2.6.1.2 Resonant Frequency, Effective Width and Effective Length.....	11
2.7 VOLTAGE STANDING WAVE RATIO AND RETURN LOSS.....	13
2.8 BANDWIDTH.....	14
2.9 DIRECTIVITY.....	14

2.10 GAIN.....	15
2.11 RADIATION PATTERN.....	15
CHAPTER THREE.....	17
DESIGN AND SIMULATION OF MULTIBAND ANTENNA	17
3.1 INTRODUCTION	17
3.2 ANTENNA DESIGN.....	18
3.2.1 Design Microstrip Antenna for Wi-Fi Device	18
3.2.2 Simulation, Results and Discussion	19
3.2.2.1 Design Rectangular Patch Antenna	19
3.2.2.2 Design Patch Antenna with Single Hexagonal Slot.....	21
3.2.2.3 Design Patch Antenna with Five Hexagons.....	23
3.2.3 Design Microstrip Antenna for Wireless Communication System.....	31
3.2.3.1 Design Microstrip Antenna with Slots in the Corners	35
3.3 DISCUSSION OF GAIN	39
CHAPTER FOUR.....	40
ANTENNA MANUFACTURING AND MEASUREMENT	40
4.1 INTRODUCTION	40
4.2 ANTENNA MANUFACTURING PROCESS	40
4.2.1 Design Microstrip Patch Antenna with Five Quad Shapes	41
4.2.2 Design Microstrip Patch Antenna with Four Hexagons Slots.....	42
4.2.3 Design Microstrip Antenna with Six Hexagons Slots	44
CHAPTER FIVE.....	46
CONCLUSION	46
REFERENCES.....	48

LIST OF TABLES

TABLE

Table 2-1. Typical applications of MSAs	6
Table 3-1. The difference between results of designs for patch antennas.	30
Table 3-2. The dimensions of proposed antenna in figure 3.20 on mm.....	31
Table 3-3. The results of designs with CPW feed.....	38
Table 4-1. The difference for return loss between simulation and measurement.	42
Table 4-2. The difference for return loss between simulation and measurement.	43
Table 4-3. The difference for return loss between simulation and measurement.	45

LIST OF FIGURES

FIGURE

Figure 2-1. Shapes of microstrip patch antennas	3
Figure 2-2. Rectangular and circular patch antennas.....	4
Figure 2-3. Geometry of microstrip patch antenna	4
Figure 2-4. Typical feeds for microstrip antennas	8
Figure 2-5. Microstrip line and its electric field lines and effective dielectric constant geometry	11
Figure 2-6. Physical and effective lengths of rectangular microstrip patch.....	12
Figure 2-7. Coordinate system for antenna analysis.....	16
Figure 3-1. Three structures of patch antenna	19
Figure 3-2. Design rectangular patch antenna without slot by HFSS	19
Figure 3-3. The return loss (S_{11}) for design patch antenna without slot	20
Figure 3-4. The gain for design patch antenna without slot	20
Figure 3-5. Design patch antenna with single hexagonal slot	21
Figure 3-6. The return loss (S_{11}) for design patch antenna with single hexagonal slot..	22
Figure 3-7. The gain for design patch antenna with single hexagonal slot	22
Figure 3-8. Design patch antenna with five hexagons	23
Figure 3-9. The return loss (S_{11}) for design patch antenna with five hexagons	23
Figure 3-10. The gain for design patch antenna with five hexagons	24
Figure 3-11. Design patch antenna with hexagon in the center and four small circles in the corners.....	24
Figure 3-12. The return loss (S_{11}) for design patch antenna with hexagon in the center and four small circles in the corners	25
Figure 3-13. The gain for design patch antenna with hexagon in the center and four small circles in the corners	25

Figure 3-14. Design patch antenna with hexagon in the center and four small quad shapes in the corners	26
Figure 3-15. The return loss (S_{11}) for design patch antenna with hexagon in the center and four small quad shapes in the corners	26
Figure 3-16. The gain for design patch antenna with hexagon in the center and four small quad shapes in the corners	27
Figure 3-17. Design patch antenna with big quad shape in the center and four small quad shapes in the corners	28
Figure 3-18. The return loss (S_{11}) for design patch antenna with big quad shape in the center and four small quad shapes in the corners	28
Figure 3-19. The gain for design patch antenna with big quad shape in the center and four small quad shapes in the corners	29
Figure 3-20. The proposed design patch antenna using CPW feed	31
Figure 3-21. The proposed design multiband patch antenna with CPW-Fed at substrate thickness 1mm	32
Figure 3-22. The return loss (S_{11}) of design has substrate thickness 1 mm	32
Figure 3-23. The gain of design has substrate thickness 1 mm	33
Figure 3-24. The proposed design multiband patch antenna with CPW-Fed at substrate thickness 1.6 mm	33
Figure 3-25. The return loss (S_{11}) of design has substrate thickness 1.6 mm	34
Figure 3-26. The gain of design has substrate thickness 1.6 mm	34
Figure 3-27. Design multiband patch antenna with CPW-Fed with four small hexagons in the corners	35
Figure 3-28. The return loss (S_{11}) of design multiband patch antenna with CPW-Fed with four small hexagons in the corners	35
Figure 3-29. The gain of design multiband patch antenna with CPW-Fed with four small hexagons in the corners	36
Figure 3-30. Design multiband patch antenna with CPW-Fed with a big hexagon instead a big rectangular and four small hexagons in the corners	36
Figure 3-31. The return loss (S_{11}) of design multiband patch antenna with CPW-Fed with a big hexagon instead a big rectangular and four small hexagons in the corners ...	37
Figure 3-32. The gain of design multiband patch antenna with CPW-Fed with a big hexagon instead a big rectangular and four small hexagons in the corners	37

Figure 4-1. Two sides of antenna manufacture.....	41
Figure 4-2. Measurement of the return loss (S_{11}).....	41
Figure 4-3. Two sides of antenna manufacture	42
Figure 4-4. Measurement of the return loss (S_{11}).....	43
Figure 4-5. Two sides of antenna manufacture	44
Figure 4-6. Measurement of the return loss (S_{11}).....	44

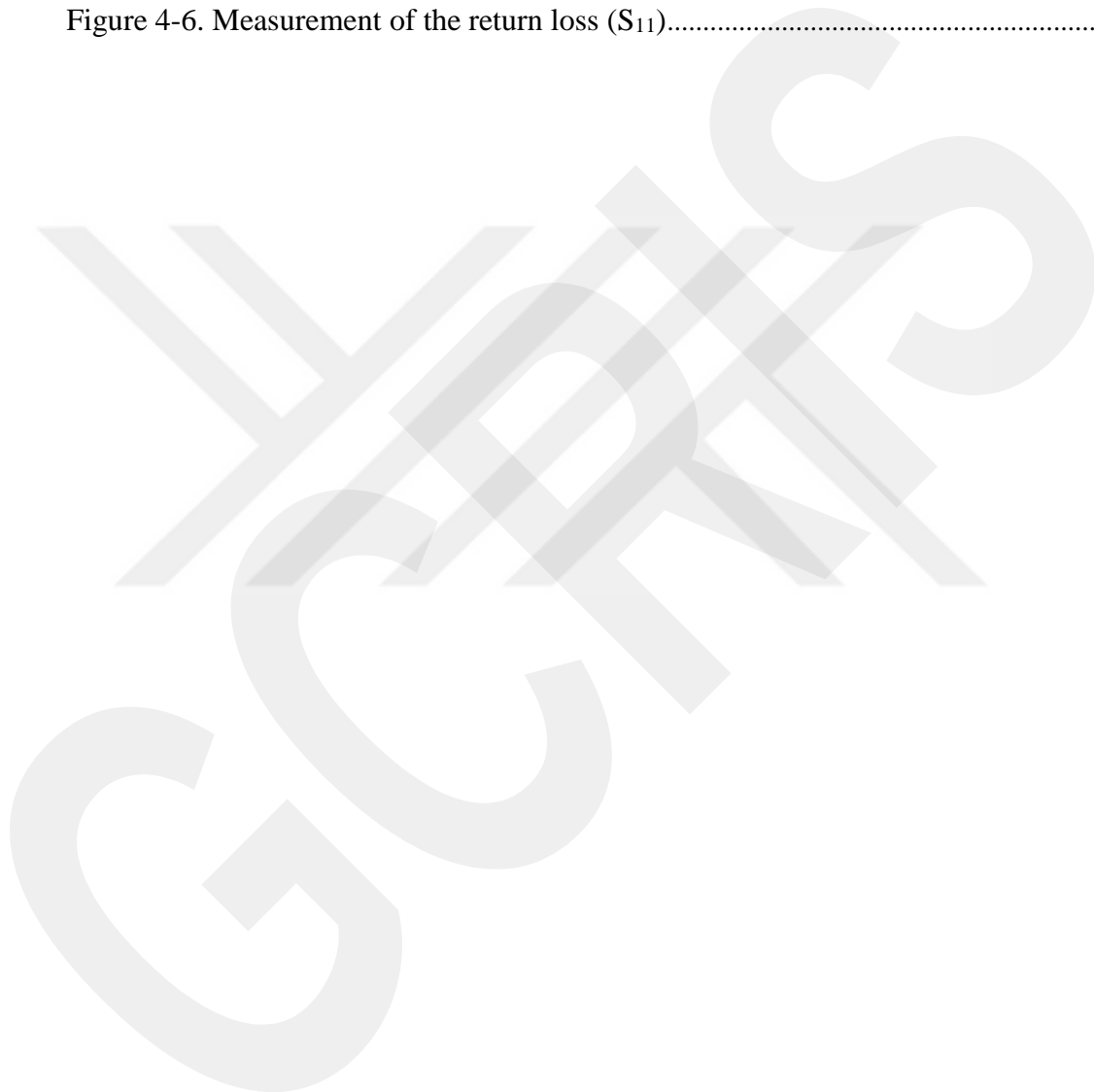

CHAPTER ONE

INTRODUCTION

Microstrip patch antenna is very prevalent primarily of the 1970s for space applications. Today, it is used for commercial and government applications. Microstrip patch antennas consist of a metal on a substrate. They are the most prevalent because of the ease of the analysis, manufacturing, and radiation characteristics attractive [1]. Antennas are important elements in systems of communication and play an important role in the signals transmission and reception. The designs of the antenna become more complicated when the requirement of new multiband and wideband are met. However, in the systems of mobile communication difficult to miniaturize circuitry size and maintain the best performance, like many operation, low cost, high efficiency, and wide band width [2]. Often the patch antennas are made in technology changer on very thin substrate buffer of different dielectric constant is bigger than two [3]. An antenna of multiband is designing to work on several bands. A multiband antenna designs a part of an active antenna and operating different active for other bands [4]. The multiband antennas have been developed recently that can be used to achieve multiband operations, such as patch antenna and slot antenna [5]. Microstrip antenna is desirable to integrate several RF modules for various frequencies in piece of equipment. Henceforth, antennas of multiband, which can be simultaneously in difference standards antennas are the focal point of many projects. Lately, researchers are becoming increasingly interested in decrease size microstrip slot antennas to fabricate small suitable for wireless applications [6]. Feeding the slots of antennas is by lines of the coplanar waveguide feed (CPW) or microstrip feed line [7, 8]. In recent years, coplanar CPW-fed printed antennas have received great attention because it has some advantages, such as ultra wide band, nice radiation properties and simple integration with system circuit [9].

The plan of this thesis designed microstrip patch antennas to achieve multiband for working on several frequencies. In the first design, we have designed microstrip patch antenna using microstrip feed line and how it works on several bands of frequency until 6 GHz. This design is using for Wi-Fi devices.

In the second design, we have designed microstrip patch antenna using coplanar waveguide feed and how it works on several bands for frequency from 1 GHz to 5 GHz. This design is using for Wireless Communication System.

Microstrip patch antennas are designed, and simulated by software program HFSS then manufactured, and tested.

This thesis includes five chapters. In the beginning in chapter one, we talk about information for microstrip patch antenna and the plan of work. In chapter two, we have put all details about the microstrip patch antenna. In chapter three, we have designed the proposed microstrip patch antennas and simulated it. In chapter four, we have compared between results in simulation and measurement for microstrip patch antenna. In chapter five, conclusion of this work.

CHAPTER TWO

MICROSTRIP ANTENNA

2.1 A HISTORY AND INFORMATION OF MICROSTRIP ANTENNA

Antennas of microstrip became most famous from into 1970s, though the concept of microstrip antennas traced in to 1953. Today it used for commercial, government application and element important in system of communication. A microstrip antenna consists of a very thin metal patch layer onto a substrate. The base substrate is a metal layer called ground. A patch form can be taken several forms. These forms can be triangle, ring, square, elliptic, disc, rectangular, pentagonal, etc. Figure 2.1 is shown forms the microstrip antenna and Figure 2.2 is shown form circle and rectangular microstrip patch antennas [1].

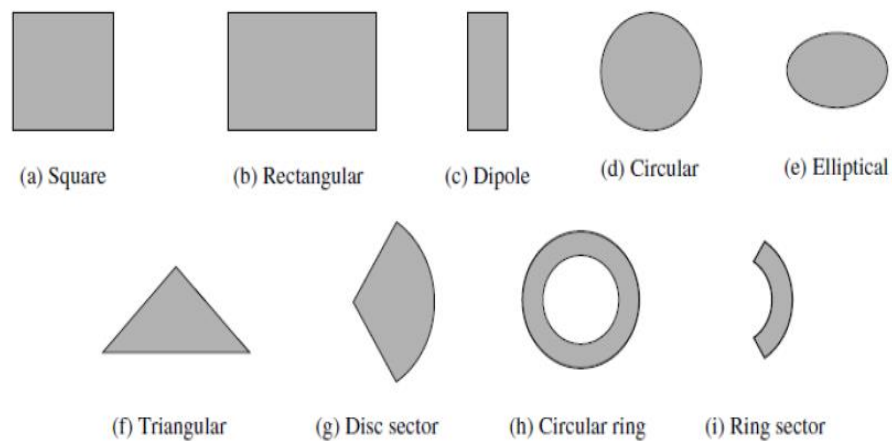
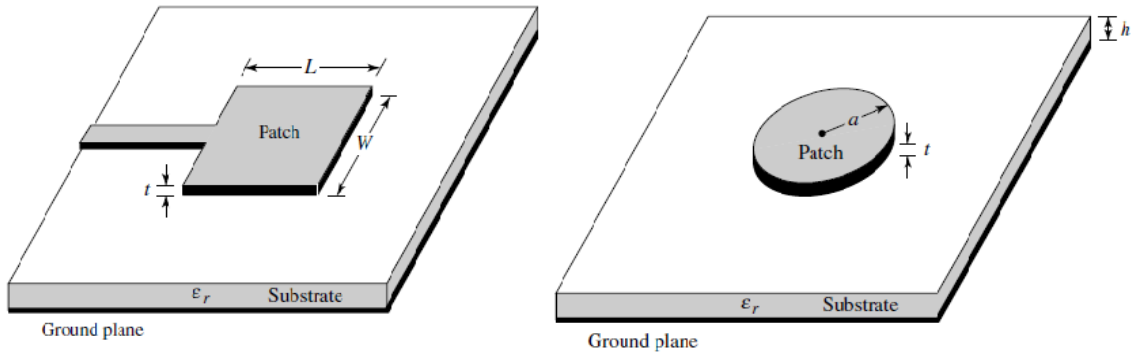

Figure 2.1. Shapes of microstrip patch antennas [1].



(a) Rectangular

(b) circular

Figure 2.2. Rectangular and circular patch antennas [1].

2.2 CHARACTERISTICS OF MICROSTRIP ANTENNA

It composes from the metal thin layer. The thickness of metal layer of the strip (patch) about ($t \ll \lambda_0$, λ_0 it is the wavelength in free space). It is position a small part of free space wavelength ($h \ll \lambda_0$, generally $0.003\lambda_0 \leq h \leq 0.05\lambda_0$) on the ground plane. At the rectangular patch, the element of length L is generally $\lambda_0/3 < L < \lambda_0/2$. Between the patch and ground layer called a substrate. The substrate has particular thickness and dielectric constant generally the range $2.2 \leq \epsilon_r \leq 12$. The substrates differ in terms of a material and a thickness. Microstrip antenna radiate from the fringing fields between the surrounding of the ground and the patch. Figure 2.3 is shown geometry of microstrip patch antenna [1].

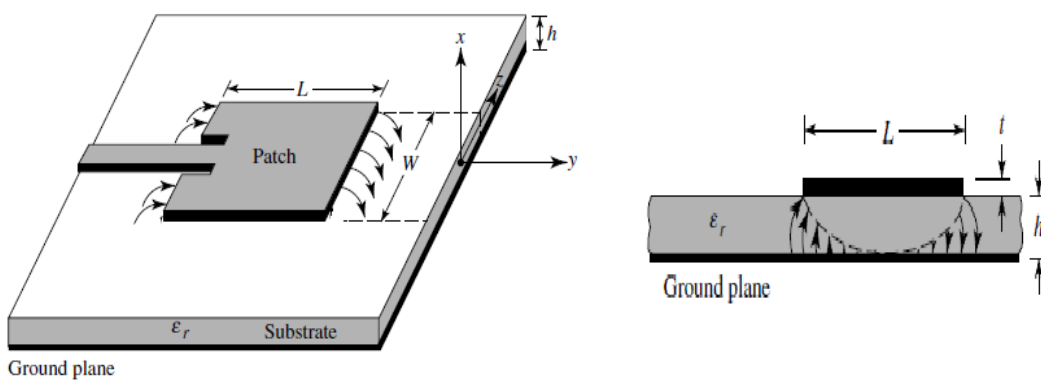

(a) Microstrip antenna

(b) Side view

Figure 2.3. Geometry of microstrip patch antenna [1].

The microstrip antennas confirm an excellent radiator for numerous applications. The reason it has many advantages however, it has disadvantages. Microstrip antenna advantages and disadvantages in the following.

2.2.1 Advantages

The microstrip antennas have several advantages. The main advantages of microstrip antennas are listed below.

- It has volume small, low profile and light weight.
- It can make conformal into the host surface.
- Inexpensive and ease of industrialization.
- It is easiness into integrate together other microwave integrated circuit on the same substrate.
- It allows for operation of dual frequency and triple frequency.

2.2.2 Disadvantages

The microstrip antennas have several disadvantages. The main disadvantages of microstrip antennas are listed below.

- Narrowness bandwidth.
- Low gain.
- Lower power-handling capability [10].
- Complex feed existences (structures) wanted for high performance arrays.

2.3 APPLICATIONS OF MICROSTRIP ANTENNA

The advantages of microstrip antenna makes it appropriate for much applications. Altitude scale of radar uses small arrays of microstrip radiator. Microstrip patch antennas are used for satellite communications and telephone. Microstrip arrays are used for satellite imaging systems. Several of applications of microstrip antennas are showing in the table below [10].

Table 2-1. Typical applications of MSAs [10].

System	Application
Aircraft and ship antennas	Communication and navigation, altimeters, blind landing systems
Missiles Satellite communications	Radar, proximity fuses and telemetry Domestic direct broadcast TV, vehicle-based antennas, communication
Mobile radio	Pagers and hand telephones, man pack systems, mobile vehicle
Remote sensing Biomedical Others	Large lightweight apertures Applicators in microwave hyperthermia Intruder alarms, personal communication, and so forth

2.4 MICROSTRIP FEED

The microstrip antenna may be excited directly through a coaxial probe or through a microstrip line. The MSA may so be excited indirectly by using electromagnetic coupling or aperture coupling and a coplanar waveguide feed (CPW) [10].

- **The microstrip feed line:** It is compacting direct with strip, generally has small width compared to the patch. It is ease of manufacture, easy at matching via controls the inset position and slightly simple to model sample.
- **Coaxial-line feeds (prob feed):** Prob feed wherever the internal conductor of the coax is united to the radiation patch that external conductor connects to the ground plane. It is ease of manufacture and matching. It has a small bandwidth and hard to model.
- **The aperture coupling :** It contains of two substrates between two layers of substrate a ground plane layer. On the undermost side of the down substrate there is a microstrip feed line whose energy combined during a slot onto the ground plane is separated the two substrates. Usually the higher dielectric constant material uses for the bottom substrate and the substrate has the lower dielectric constant material uses for the top substrate [1].
- **The proximity coupling:** It has the wide bandwidth, a little easy to model and the spurious radiation in this type of feed is low, but its manufacturion is quite difficult [1].
- **The coplanar waveguide (CPW) feed:** The CPW-fed contains of conductor strip in the middle. The coplanar waveguide feeding technicality provides many advantages over microstrip line feed, like low dispersion, low radiation leakage and simple of integration with active devices [11].

These types of feed described above are shown in Figure 2.4 following.

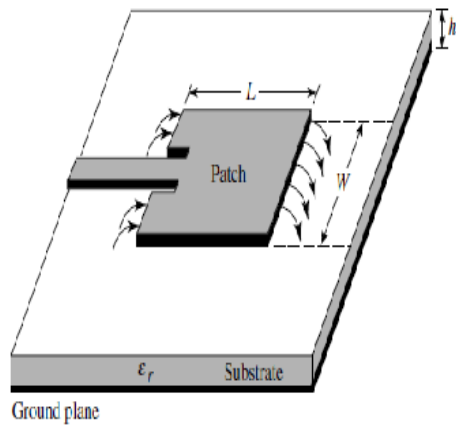

(a) Microstrip line feed [1]

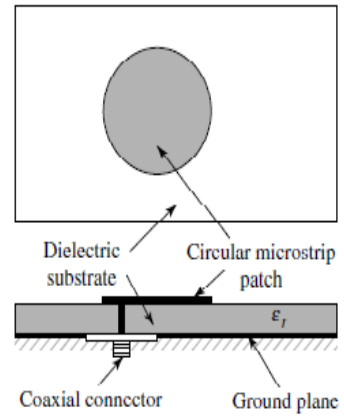

(b) Probe feed [1]

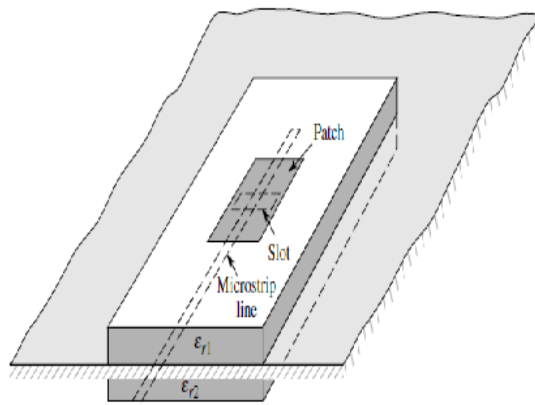

(c) Aperture-coupled feed [1]

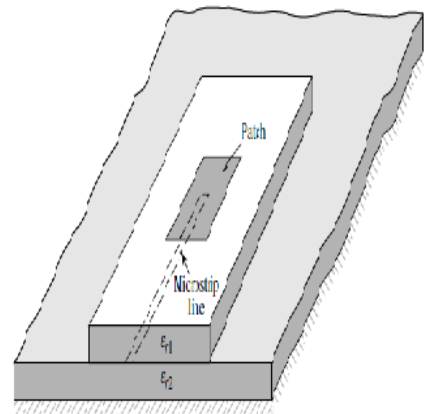

(d) Proximity-coupled feed [1]

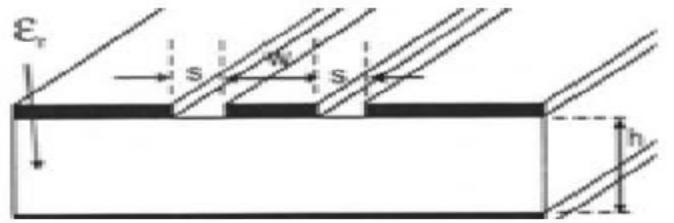

(e) Coplanar waveguide (CPW) [11]

Figure 2.4. Typical feeds for microstrip antennas.

2.5 METHODS OF ANALYSIS

The transmission line, cavity, and full wave are famous models for microstrip antennas analysis. The simplest model for all methods of analysis is the transmission line model because it gives a better physical insight but it is less accurate. Another model, the cavity model gives a better physical insight the same the transmission line in this side. The cavity model is more accurate but is complex in nature. The full wave models are much versatile, much accurate, treat single elements, stacked elements, finite and infinite arrays, arbitrary shaped, elements and coupling [12].

2.6 RECTANGULAR PATCH

The rectangular patch is used widely configuration. It is the simplest to analysis when using both the transmission line model and the cavity model, which are the most accurate for thin substrates. We will talk about the transmission line model because we have used this model for designs antennas in this thesis [1].

2.6.1 Transmission Line Model:

The transmission line model is the simplest model of all but the lowest accurate results and it lacking versatility. However, it gives good physical insight.

A rectangular microstrip antenna can represent as an array of two radiate narrow slots, each of width W and height h , separated by a low-impedance Z_c transmission line of length L .

2.6.1.1 Fringing Effects:

The fields at the edges of the patch undergo fringing because the patch dimensions are finite for the length and the width. This is explained along the length in Figures 2.3(a,b) for the radiating slots are two of the microstrip antenna. Also applies along the width. Fringing amount is a function of patch dimensions and the height of the substrate.

The following Figure 2.5 is shown a microstrip line antenna is shown in Figure 2.5(a), electric field lines are Fractions of some of electric field lines exist in air and the most of lines reside in the substrate is shown in Figure 2.5(b). As the ratio of the width of the patch W to the height h of the substrate ($W/h \gg 1$) and the dielectric constant ($\epsilon_r \gg 1$), the lines of electric field are concentrated mostly in the substrate.

The effective dielectric constant defined as the dielectric constant of uniform dielectric material and it has value in the range closer to the value of the actual dielectric constant of the substrate $1 < \epsilon_{eff} < \epsilon_r$, as it is shown in Figure 2.5(c).

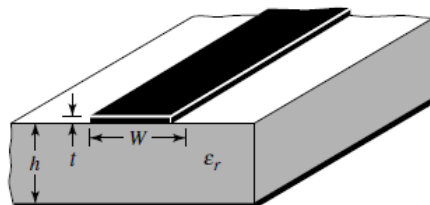

(a) Microstrip line [1]



(b) Electric field lines [1]

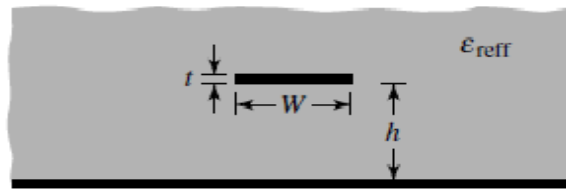

(c) Effective dielectric constant [1]

Figure 2.5. Microstrip line and its electric field lines and effective dielectric constant geometry.

The effective dielectric constant is the function of the relationship for the dielectric constant of the substrate, the width of strip and even the thickness of strip shown in the equation as:

$$\epsilon_{\text{reff}} = \frac{\epsilon_r + 1}{2} + \frac{\epsilon_r - 1}{2} \left[1 + 12 \frac{h}{w} \right]^{-0.5}, \frac{w}{h} > 1 \quad (2.1)$$

Where ϵ_r the dielectric constant of the substrate, w is the width of the patch, and h is the height (thickness) of the substrate [1].

2.6.1.2 Resonant Frequency, Effective Width, and Effective Length:

We can calculate the resonant frequency when the length of the patch is known from equation following:

$$f = \frac{c}{2 * L * \sqrt{\epsilon_r}} \quad (2.2)$$

Where c is velocity in free space of light, L is the length of the patch, and ϵ_r is the dielectric constant of the substrate [1].

The equation formula for the calculate the width of the patch is:

$$W = \frac{c}{2 * f} * \sqrt{\frac{2}{\epsilon_r + 1}} \quad (2.3)$$

Where c is velocity in free space of light, f is the resonant frequency, and ϵ_r is the dielectric constant of the substrate [1].

In Figure 2.6 where the patch length has been extended on each end by a distance ΔL , which is a function shown relation for the extension of the length is:

$$\Delta L = \frac{0.412 * h * (\epsilon_{reff} + 0.3) * (\frac{W}{h} + 0.264)}{(\epsilon_{reff} - 0.258) * (\frac{W}{h} + 0.8)} \quad (2.4)$$

Where h is the thickness of substrate, ϵ_{reff} is the effective dielectric constant, and W is the width of the patch [1].

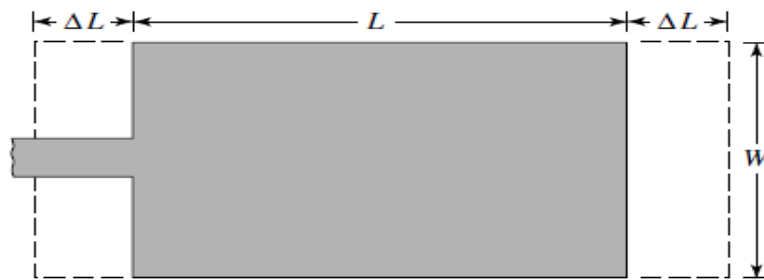

(a) Top view [1]

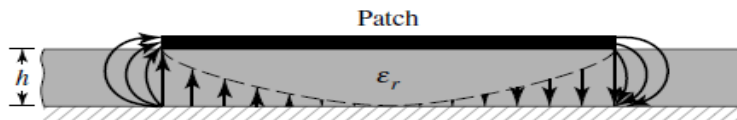

(b) Side view [1]

Figure 2.6. Physical and effective lengths of rectangular microstrip patch.

The equation of the effective length of the patch whereas ($L = \lambda/2$ for dominant TM_{010} mode with no fringing) is:

$$L_{eff} = \frac{c}{2 * f * \sqrt{\epsilon_{reff}}} \quad (2.5)$$

Where f is the resonant frequency, c is the speed of the light in free space [1].

The equation for calculate the length of the patch is [1]:

$$L = L_{eff} - 2 * \Delta L \quad (2.6)$$

2.7 VOLTAGE STANDING WAVE RATIO AND RETURN LOSS

The ratio of the maximum to minimum voltage of the antenna is called voltage standing wave ratio (VSWR). A ratio between incident wave amplitude (v_i) and reflected voltage wave amplitude (v_r) is called the reflection coefficient (ρ). As shown following [13]:

$$\Gamma = \frac{Z_{input} - Z_0}{Z_{input} + Z_0} \quad (2.7)$$

Where Z_0 is the characteristic impedance of the antenna. The reflection coefficient ρ is absolute value of magnitude of Γ .

$$\rho = |\Gamma| = \frac{VSWR - 1}{VSWR + 1} \quad (2.8)$$

Consequently,

$$VSWR = \frac{|\Gamma| + 1}{|\Gamma| - 1} \quad (2.9)$$

2.8 BANDWIDTH

An antenna bandwidth defined as “the frequencies range within that the performance of the antenna, with respects to some characteristic, corresponds to a specified standard”. The antenna bandwidth is the range of frequencies on each side of a centre frequency (ordinarily the resonant frequency for the dipole). For broadband antennas, the bandwidth is ordinarily said to be the ratio of the upper – to – lower frequencies of agreeable operation that shown below [1]:

$$BW_{\text{broadband}} = \frac{f_H}{f_L} \quad (2.10)$$

Where BW is the antenna bandwidth, f_H is the higher frequency, and f_L is the lower frequency.

For narrowband antennas, the bandwidth is said to be a percentage for difference for frequency (upper minus lower) divided the centre frequency of bandwidth that explained below [12]:

$$BW_{\text{narrowband}} (\%) = \left[\frac{f_H - f_L}{f_C} \right] * 100 \quad (2.11)$$

Where BW is the antenna bandwidth, f_H is the higher frequency, f_L is the lower frequency, and f_C is the centre frequency.

2.9 DIRECTIVITY

Antenna directivity defined as “the ratio of the radiation intensity in a certain direction from the antenna to the radiation intensity averaged over all directions”. The average radiation intensity is equal to the overall power radiated by the antenna divided by 4π .

$$D = \frac{U}{U_0} = \frac{4 * \pi * U}{P_{\text{rad}}} \quad (2.12)$$

Where D is directivity, U is radiation intensity (W per unit solid angle), U_0 is the radiation intensity of an isotropic source (W per unit solid angle), and P_{rad} is over all radiation power (W) [1].

2.10 GAIN

The gain is measured describing the performance of an antenna. The antenna gain is most related to the directivity.

An antenna gain defined as “the ratio of the intensity, in certain direction, to the radiation intensity obtained if the power is acceptable by the antenna radiated isotropically. The radiation intensity corresponding to the isotropically radiated power is equal to the input power by the antenna divided by 4π ”. The equation for gain antenna given as [1]:

$$\text{Gain} = 4\pi * \frac{\text{radiation intensity}}{\text{total input (accepted) power}} = 4\pi * \frac{U(\theta, \phi)}{P_{in}} \quad (2.13)$$

2.11 RADIATION PATTERN

Pattern of an antenna defined as “a mathematical function or a graphical representation of the radiation properties of the antenna as a function of space coordinates. The pattern determines in the far field and represents as a function of the directional coordinates. The properties for the radiation pattern are included power flux density, field strength, radiation intensity, directivity, phase or polarization”. The radiation of most attention is the two or three dimensional spatial distribution of radiated energy as a function of the observer’s position along a path or surface of constant radius. Coordinate systems for antenna analysis shown in Figure 2.7 following.

CHAPTER THREE

DESIGN AND SIMULATION OF MULTIBAND ANTENNA

3.1 INTRODUCTION

A microstrip antenna is an important element and main objective in the wireless applications system. It is widely used because it has small volume, light weight, low profile, and low cost. The rectangular patch antenna is a kind of radio antenna. It contains of the metal layer called patch over another called ground, between two layers of metal the substrate has thickness and dielectric constant. The thickness and dielectric constant for substrate are various from one design to another. In this chapter; we include two designs for rectangular microstrip antenna. The first design, patch antenna design is used microstrip line feed. The most used a rectangular patch of microstrip antenna which looks like a truncated microstrip line feed. The second design, patch antenna design used coplanar wave guide (CPW) feed. A considered two designs for microstrip patch antenna is considered for multiband operation. Used soft ware HFSS (High Frequency Simulator Structure) for design and simulation.

3.2 ANTENNA DESIGN

3.2.1 Design Microstrip Antenna for Wi-Fi Device

A compact patch antenna [15] with a wide slots of hexagonal shape with microstrip line feed for multiband operation for Wi-Fi devices is simulated as a first step. It is printed on thickness is 1.6 mm FR4 substrate with relative dielectric constant of the FR4 is 4.4. The rectangular patch dimension is calculated by the resonant frequency at 2.4 GHz used equations from (2.1) to (2.6) and the frequency band until 6 GHz. We have designed three structure of patch antenna. The first structure, simple rectangular of patch has length is 28 mm and width is 38 mm and we have used full cover ground plane. The techniques of the feeding are used in all structure in this proposed is made up of a 50 Ω microstrip feeding line. The dimensions for the microstrip feed linear 3 \times 10 mm². The dimensions of the microstrip feed line in all structures are at the same distance. The second structures addition a single hexagonal slot on the Centre of the rectangular patch, the hexagonal dimension is 10 mm. The third structure, addition five hexagon slots with a rectangular patch, in which one hexagon in the Centre has the same dimension in the second structure and dimensions of another four hexagons is 10/3 mm. These four slots are symmetrically located at the coordinates at (9, 12), (9,-12), (-9, 12), and (-9,-12). The proposed work structures are shown in Figure 3.1 following. We have designed three structures and have simulated. Then in forth structure, we have designed microstrip patch antenna with single hexagonal in the center and four circle slot in the corners. The radius of circles in the corners is 3mm and the dimension of hexagonal is 10 mm. Then we have designed microstrip patch antenna with hexagonal in the center and four quad shapes slots in the corners. The radius of quad shapes in the corners is 2 mm and the hexagonal dimension is 10 mm. Finally, we have designed microstrip patch antenna with big quad shape slot in the center has radius 7 mm and four small quad shapes slot in the corners have radius 2 mm.

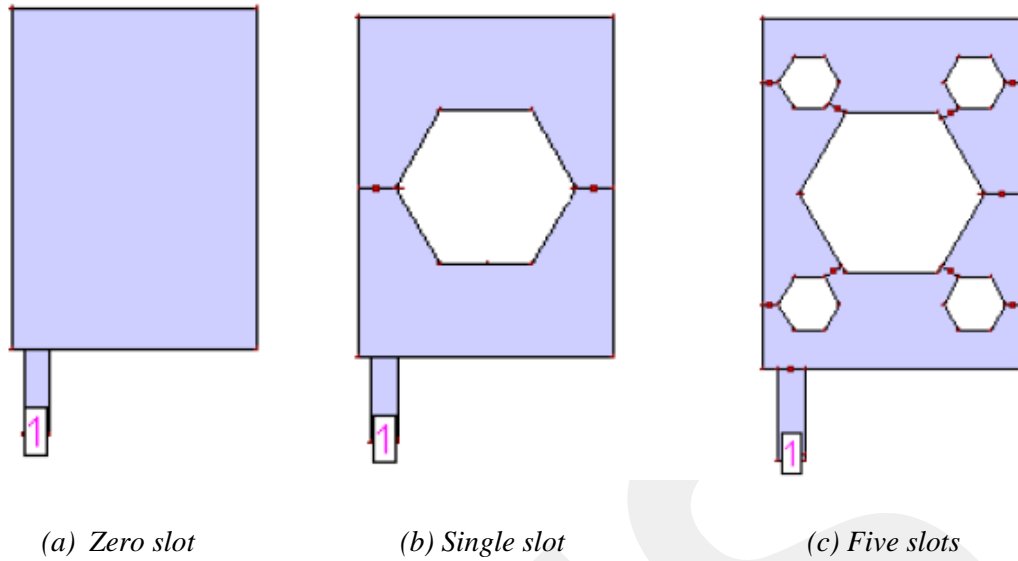

Figure 3.1. Three structures of patch antenna [15].

3.2.2 Simulation, Results and Discussion

In this thesis, we have used software programs HFSS (High Frequency Simulator structure) to design and simulation patch antenna.

3.2.2.1 Design Rectangular Patch Antenna

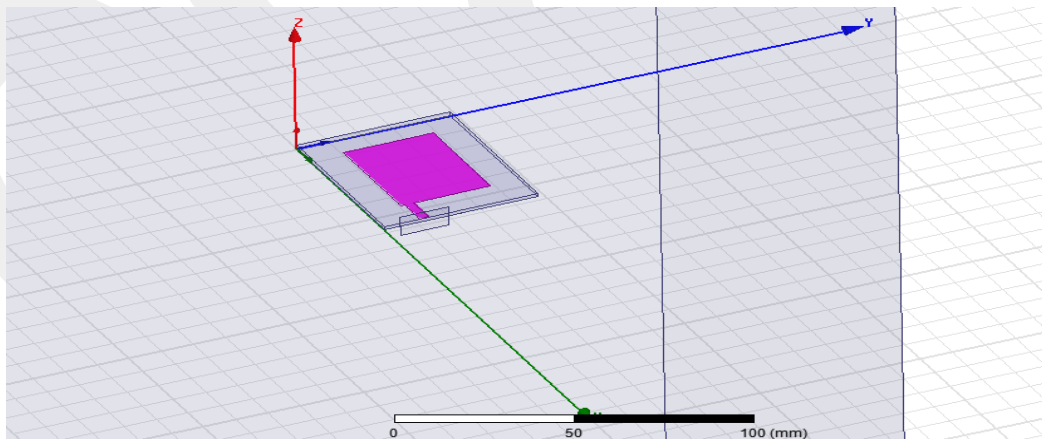

Figure 3.2. Design rectangular patch antenna without slot by HFSS.

Initially, we have designed rectangular patch antenna without slot on patch dimensions are $38 \times 28 \times 1.6 \text{ mm}^3$ using soft ware program HFSS and simulation.

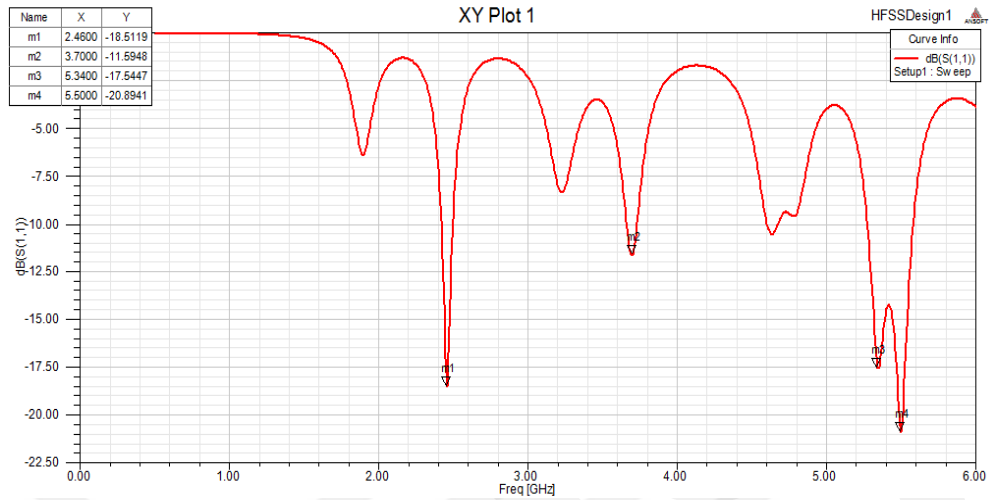

Figure 3.3. The return loss (S_{11}) for design patch antenna without slot.

The modified of slot is randomly until a specific return loss value of return loss S_{11} must be less than -10 dB. In this design, the results of return loss are -18 dB, -11 dB, -17 dB, and -20 dB at frequencies 2.4 GHz, 3.7GHz, and (5.3-5.5GHz) in the order. This design operates multiband of frequencies.

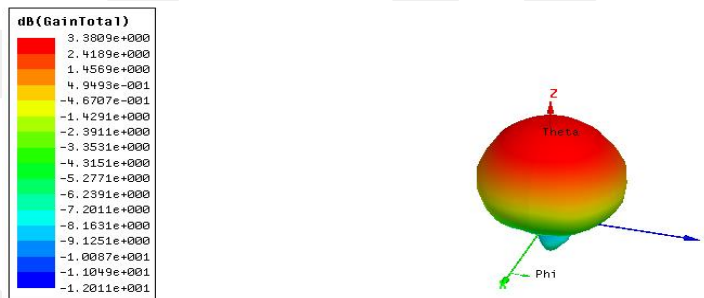

Figure 3.4. The gain for design patch antenna without slot.

In Figure 3.4, it is shown the power gain of design microstrip antenna without slot describes performance this antenna. One of disadvantages for microstrip antenna has low gain. In this design seems a good gain.

3.2.2.2 Design Patch Antenna with Single Hexagonal Slot

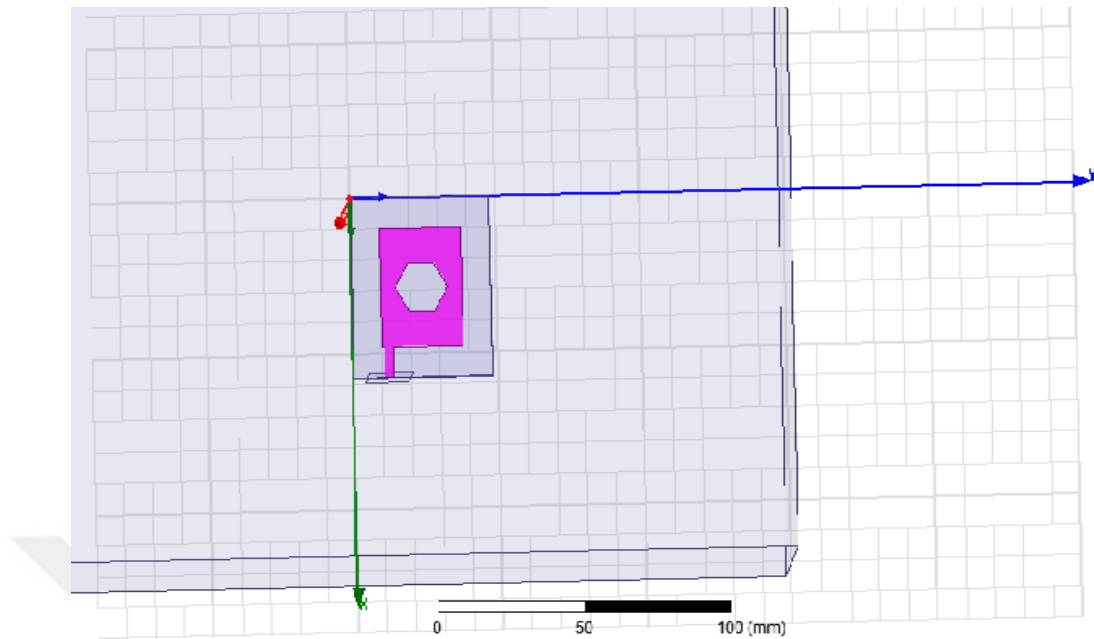

Figure 3.5. Design patch antenna with single hexagonal slot.

In this structure, we have designed rectangular microstrip patch antenna and added single hexagonal slot in the center of the patch and simulated as in ref [15]. The patch antenna dimensions are $38 \times 28 \times 1.6 \text{ mm}^3$ and hexagonal slot dimension is 10 mm.

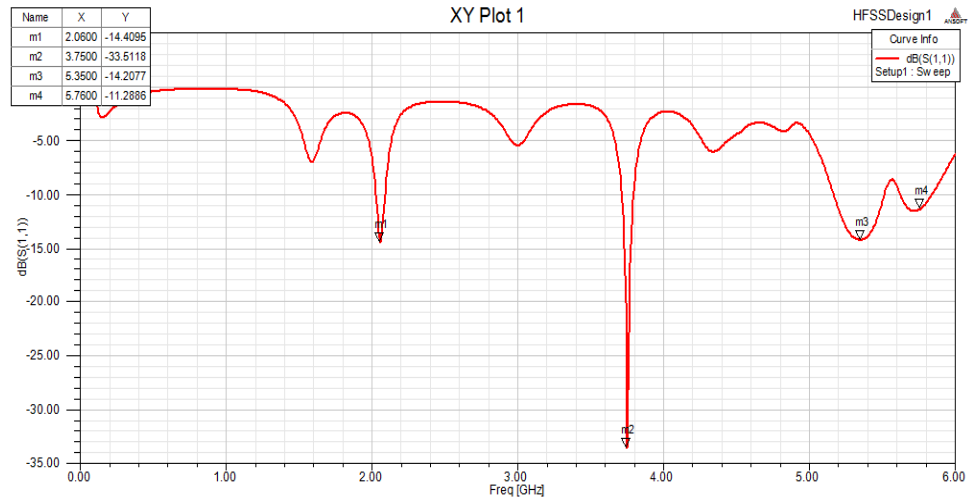

Figure 3.6. The return loss (S_{11}) for design patch antenna with single hexagonal slot.

In Figure 3.6, it is shown operating frequencies at the design in Figure 3.5. Results of return loss are -14.4 dB, -33.5 dB, -14 dB, and -11 dB at frequencies 2.06 GHz, 3.75 GHz, 5.35 GHz, and 5.76 GHz in the order. This design operates multiband of frequencies.

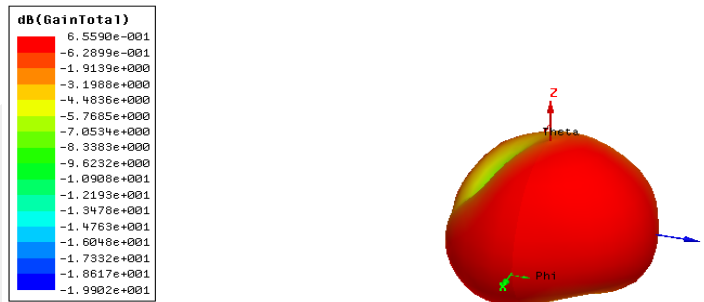

Figure 3.7. The gain for design patch antenna with single hexagonal slot.

In Figure 3.7, it is shown the gain of design microstrip antenna with single hexagonal slot in the center describes performance this antenna. In this design seems a poor gain.

3.2.2.3 Design Patch Antenna with Five Hexagons

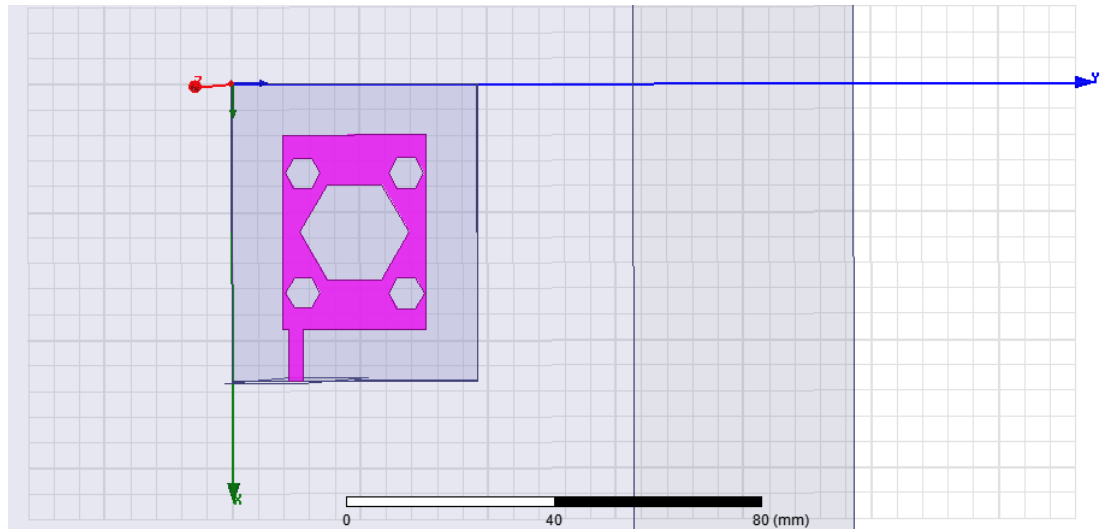

Figure 3.8. Design patch antenna with five hexagons.

In this structure, we have designed rectangular microstrip patch antenna and added hexagonal slot in the center of the patch as in [15]. The patch antenna dimensions are $38 \times 28 \times 1.6 \text{ mm}^3$ and hexagonal slot in the center dimension is 10 mm. And we have added four hexagons in the four corners. The dimension of four hexagons in the four corners is $10/3 \text{ mm}$.

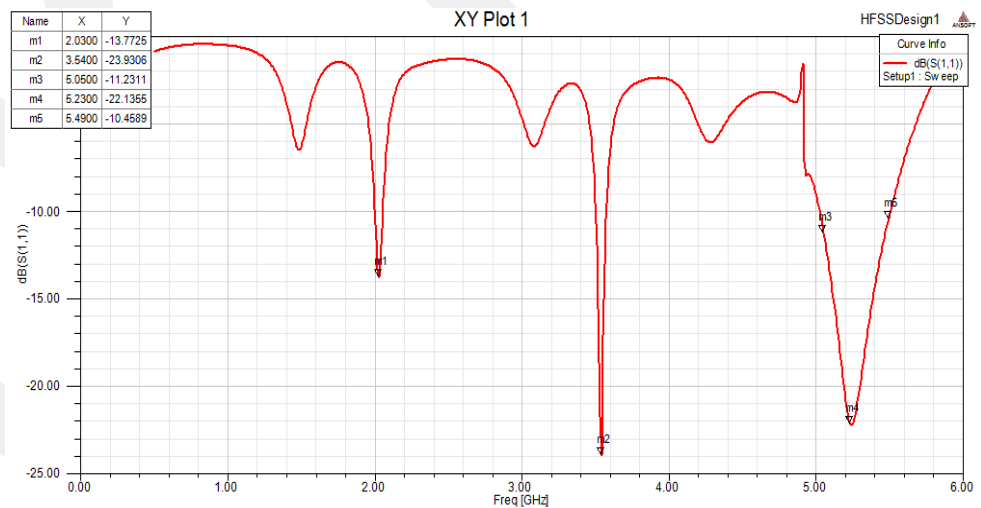

Figure 3.9. The return loss (S_{11}) for design patch antenna with five hexagons.

In Figure 3.9, it is shown operating frequencies at the design in Figure 3.8. The results of return loss are -13 dB, -23.9 dB, and -22 dB at frequencies 2.03 GHz, 3.5 GHz, and 5.23 GHz in the order. This design operates multiband of frequencies.

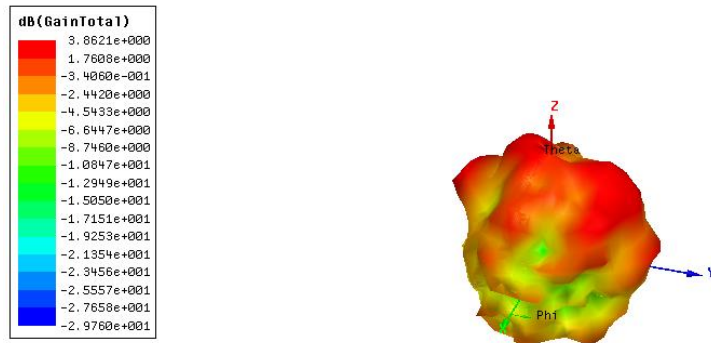

Figure 3.10. The gain for design patch antenna with five hexagons.

In Figure 3.10, it is shown the gain of design microstrip antenna with five hexagonal slots describes performance this antenna. In this design seems a good gain.

Then we changed the antenna design, the hexagons in the corners are replaced with the circles shapes.

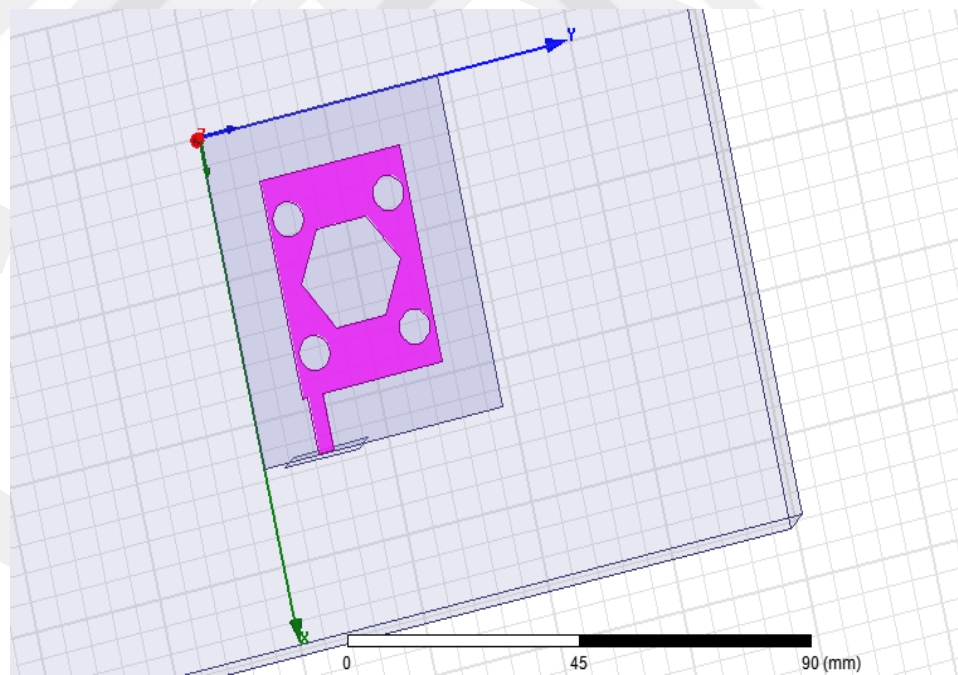

Figure 3.11. Design patch antenna with hexagon in the center and four small circles in the corners.

In this structure, we have designed rectangular microstrip patch antenna and added hexagonal slot in the center of the patch. The patch antenna dimensions are $38 \times 28 \times 1.6 \text{ mm}^3$ and hexagonal slot in the center dimension is 10 mm. And we have added four circles in the four corners. The radius of the circles in the corners is 3 mm.

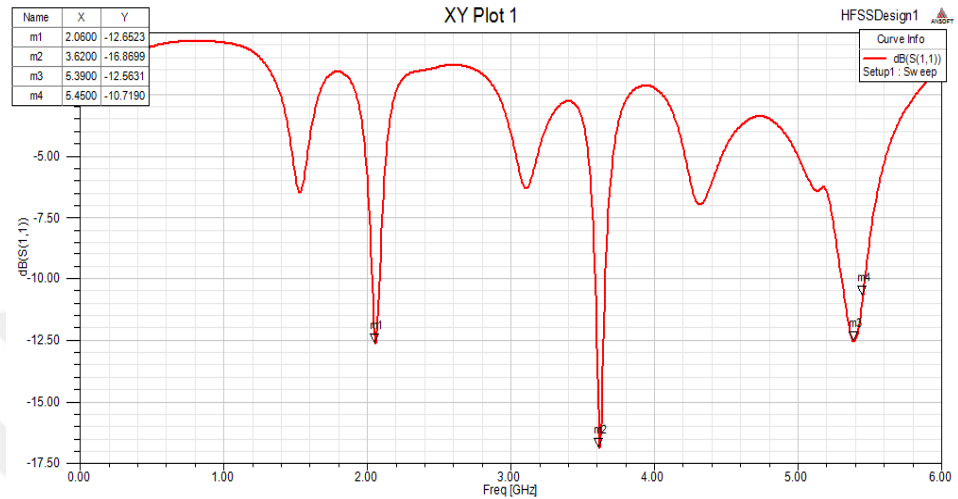

Figure 3.12. The return loss (S_{11}) for design patch antenna with hexagon in the center and four small circles in the corners.

In Figure 3.12, it is shown operating frequencies at the design in Figure 3.11. The results of return loss are -12.6 dB, -16.86 dB, and -12 dB at frequencies 2.06 GHz, 3.6 GHz, and 5.39 GHz in the order. This design operates multiband of frequencies.



Figure 3.13. The gain for design patch antenna with hexagon in the center and four small circles in the corners.

In Figure 3.13, it is shown the gain of design microstrip antenna with hexagon in the center and four small circles in the corners describes performance this antenna. In this design seems a good gain.

Then we changed the antenna design, the circles in the corners are replaced with the quad shapes.

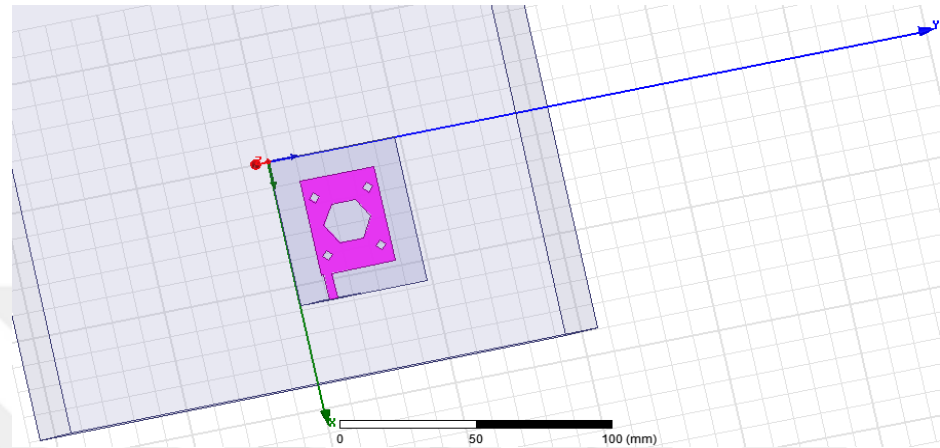

Figure 3.14. Design patch antenna with hexagon in the center and four small quad shapes in the corners.

In this structure, we have designed rectangular microstrip patch antenna and added hexagonal slot in the center of the patch. The patch antenna dimensions are $38 \times 28 \times 1.6 \text{ mm}^3$ and hexagonal slot in the center dimension is 10 mm. And we have added four quad shapes in the four corners. The radius of the quad shapes in the corners is 2 mm.

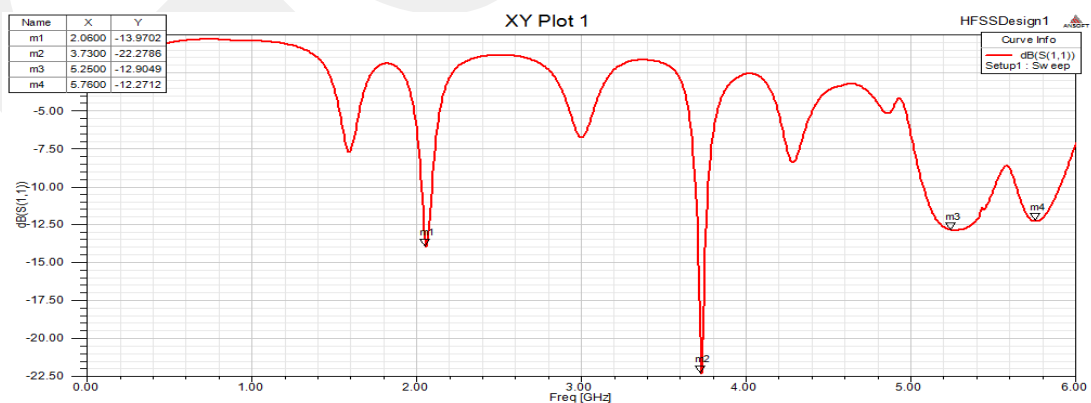

Figure 3.15. The return loss (S_{11}) for design patch antenna with hexagon in the center and four small quad shapes in the corners.

In Figure 3.15, it is shown operating frequencies at the design in Figure 3.14. The results of return loss are -13.9 dB, -22 dB, -12.9 dB, and -12.27 dB at frequencies 2.06 GHz, 3.73GHz, 5.25 GHz, and 5.7 GHz in the order. This design operates multiband of frequencies.

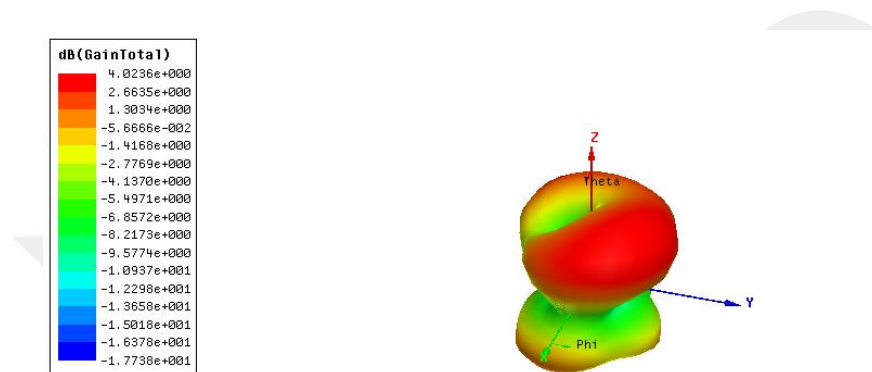

Figure 3.16. The gain for design patch antenna with hexagon in the center and four small quad shapes in the corner.

In Figure 3.16, it is shown the gain of design microstrip antenna with hexagon in the center and four small quad shapes in the corner describes performance this antenna. In this design seems a good gain.

Then we changed the design antenna, the hexagonal in the center is replaced with quad shape.

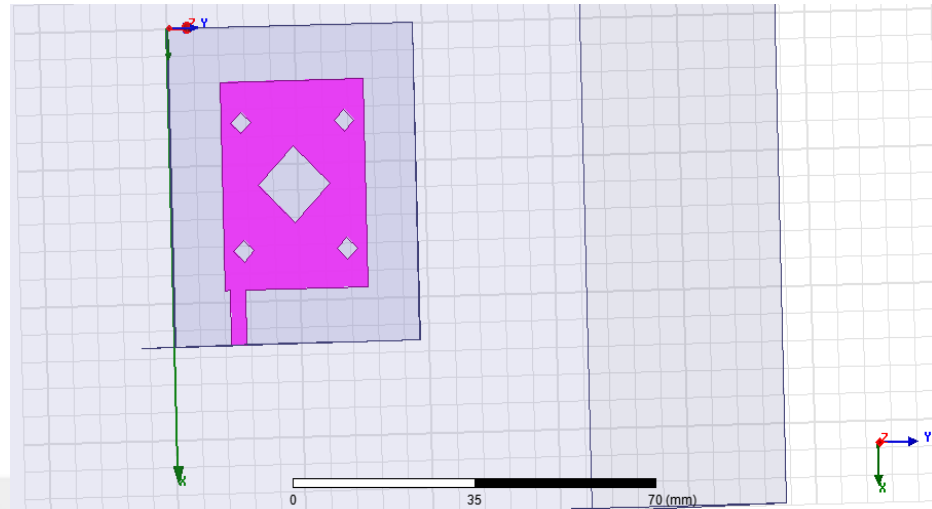

Figure 3.17. Design patch antenna with big quad shape in the center and four small quad shapes in the corners.

In this design, we have designed rectangular microstrip patch antenna and added big quad shape slot in the center of the patch. The patch antenna dimensions are $38 \times 28 \times 1.6 \text{ mm}^3$ and big quad shape slot in the center of the patch dimension is 7 mm. And we have added four quad shapes in the four corners. The radius of the quad shapes in the corners is 2 mm.

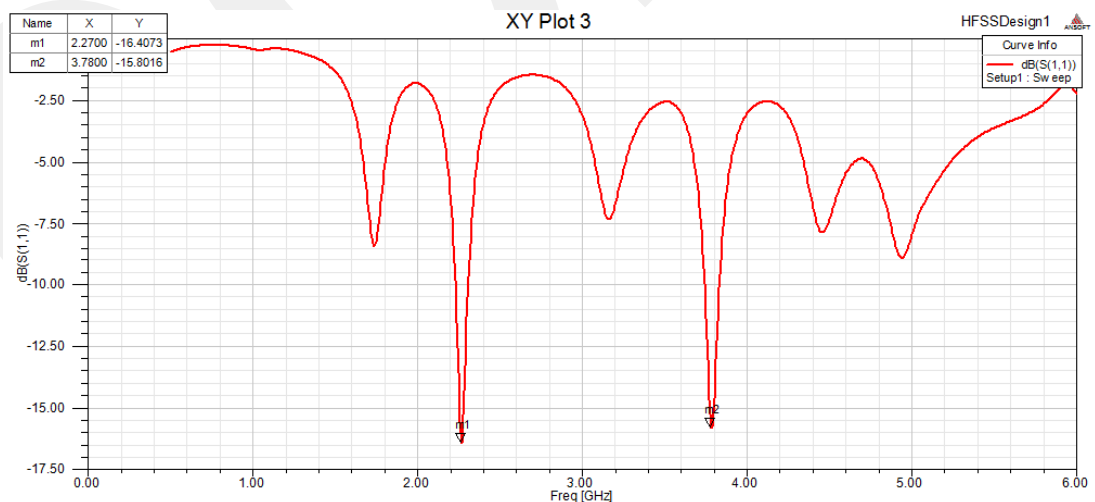

Figure 3.18 The return loss (S_{11}) for design patch antenna with big quad shape in the center and four small quad shapes in the corners.

In Figure 3.18, it is shown operating frequencies at the design in Figure 3.17. The results of return loss are -16 dB, and -15.8 dB at frequencies 2.27 GHz, and 3.78 GHz. This design operates multiband of frequencies.

This design will be manufactured and compared with results in simulation and measurement. It is shown that comparison in chapter four.

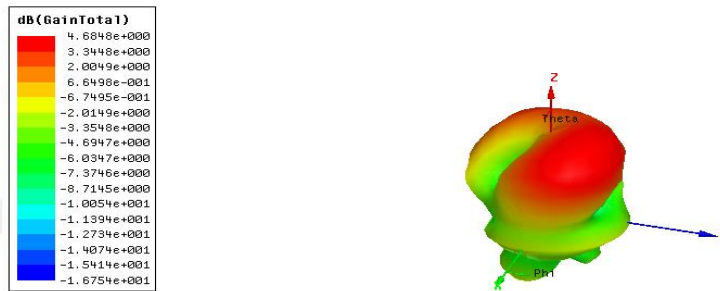

Figure 3.19. The gain for design patch antenna with big quad shape in the center and four small quad shapes in the corners.

In Figure 3.19, it is shown the gain of design microstrip antenna with big quad shape in the center and four small quad shapes in the corners describes performance this antenna. This design has a good gain.

Table 3-1. The difference between results of designs for patch antennas.

Design	Resonance frequencies (GHz)	Return loss (dB)	Gain (dB)
Figure 3.2.	2.4	-18.5	3.38
	3.7	-11	
	(5.3-5.5)	(-17 - -20)	
Figure 3.5.	2.06	-14.4	0.6
	3.75	-33.5	
	5.35	-14	
	5.76	-11	
Figure 3.8.	2.03	-13.7	3.8621
	3.5	-23.9	
	5.23	-22	
Figure 3.11.	2.06	-12.6	4.7589
	3.6	-16.8	
	5.39	-12	
Figure 3.14.	2.06	-13.9	4.0236
	3.7	-22	
	5.25	-12.9	
	5.76	-12	
Figure 3.17.	2.27	-16	4.6848
	3.78	-15.8	

In the table 3.1 above, the results for simulation of designs are showing. We have seen all designs operated multiband frequencies and the results between (2 GHz-5.8GHz). We have seen agreement for results of frequencies between design microstrip patch antenna with single hexagonal in the center of the patch shown in Figure 3.5 and design microstrip patch antenna with hexagon in the center and four small quad shape in the corner shown in Figure 3.14 but the gain improved in design microstrip patch antenna with hexagon in the center and four small quad shape in the corner.

3.2.3 Design Microstrip Antenna for Wireless Communication System

A rectangular patch antenna on thickness 1 mm FR4 substrate with relative dielectric constant of 4.4 is simulated as in [2]. The resonance frequencies of the design are 2.47, 3.02, and 4.13 GHz, which results in (1.5-4.8) GHz at band frequency from 1 GHz to 5 GHz and the size of patch is $70 \times 180 \text{ mm}^2$ and have used half covering ground plane. Figure 3.20 shows the configuration of a multiband with a 50Ω CPW feeding line slot antenna. We have designed and simulated microstrip patch antenna on thickness of substrate 1 mm using the dimensions in the table 3.2. Then we have increased the thickness of substrate from 1 mm to 1.6mm and simulated. Then we have changed the design antenna, we have added four hexagons slot in four corners. The dimension of hexagons is $10/3 \text{ mm}$. This design is simulated, manufactured and measured. Finally, we have changed the antenna design two hexagons instead two rectangles. This design is simulated, manufactured and measured. Then we have compared the results of simulation and measurement as shown in chapter four.

We have used program software HFSS (High Frequency Simulator Structure) for antenna design and simulation. This design is using for Wireless Communication System.

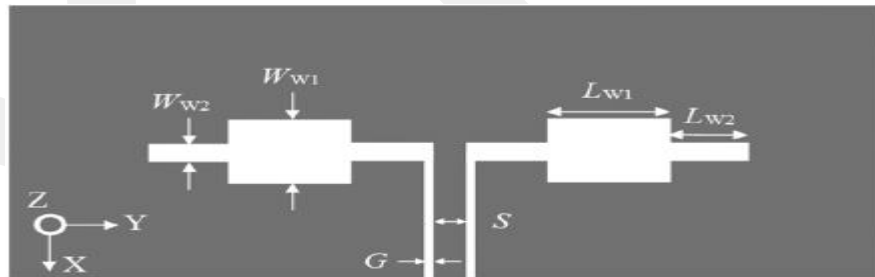

Figure 3.20. The proposed design patch antenna using CPW feed [2].

Table 3-2. The dimensions of proposed antenna [2] in figure 3.20 on mm.

L_{w1}	L_{w2}	W_{w1}	W_{w2}	S	G
32.6	16.3	29	3.4	3.66	0.3

In the first, we have design the proposed design using 1 mm substrate thickness.

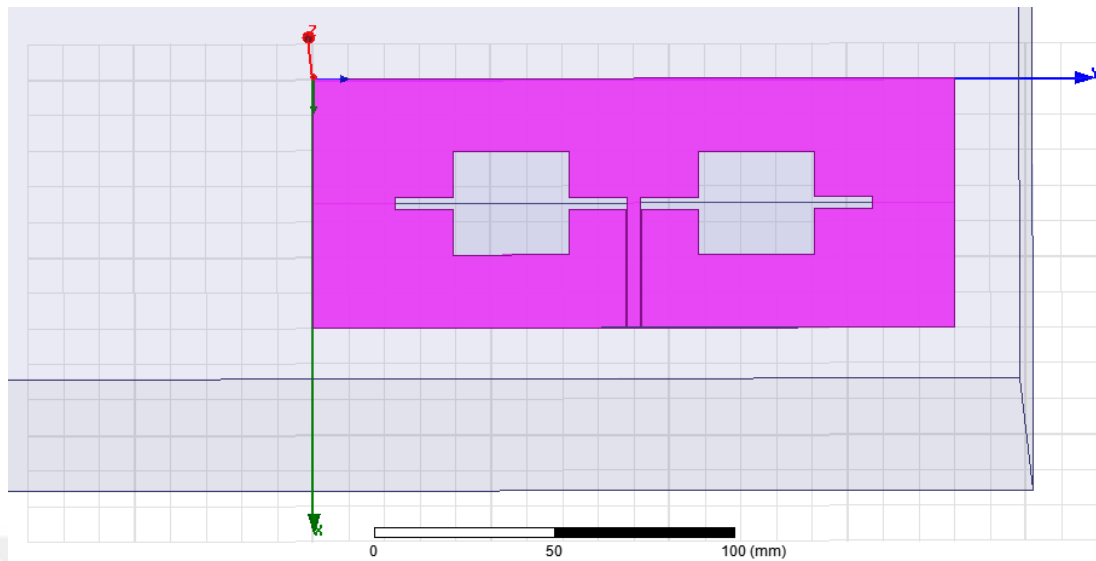

Figure 3.21. The proposed design multiband patch antenna with CPW-Fed at substrate thickness 1mm.

We designed and simulated the microstrip patch antenna [2]. The dimensions of microstrip patch antenna are $70 \times 180 \times 1 \text{ mm}^3$ and the same geometry dimensions are shown in the table 3.2. Then, we repeat design and simulate on the same geometry but we have changed the thickness of FR4 substrate to become 1.6 mm. It is shown in Figure 3.24 below.

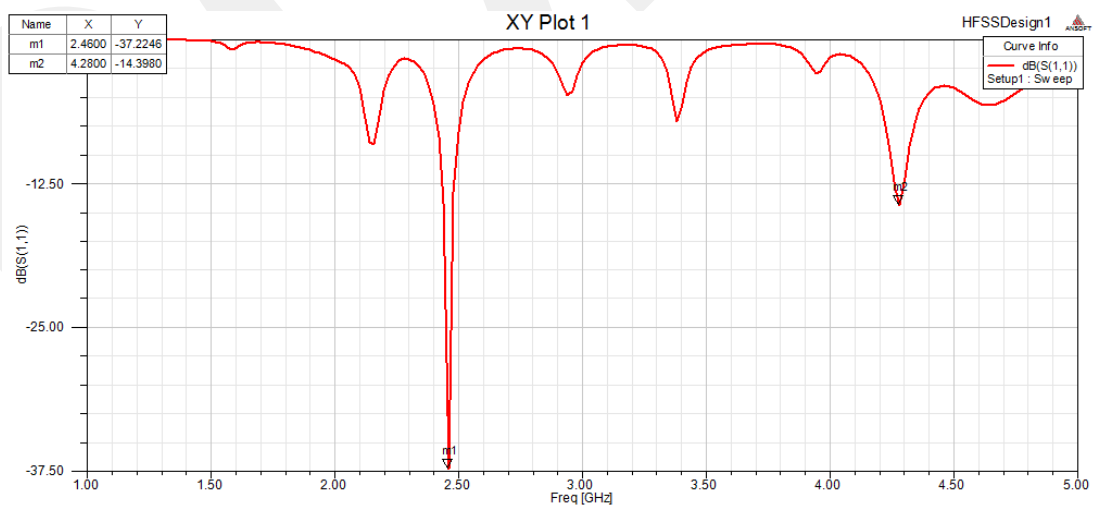

Figure 3.22. The return loss (S_{11}) of design has substrate thickness 1 mm.

In Figure 3.22, it is shown operating frequencies at the design in Figure 3.21. The results of return loss are -37 dB, and -14 dB at frequencies 2.46 GHz, and 4.2 GHz in the order. Then comparison between results of designs when change thickness of substrate and have changed shape of slots, that is shown below.



Figure 3.23. The gain of design has substrate thickness 1 mm.

In Figure 3.23, it is shown the gain of the proposed design multiband patch antenna with CPW-Fed at substrate thickness 1mm describes performance this antenna. In this design seems a good gain.

Secondly, we have changed the thickness of substrate from 1 mm to 1.6 mm.

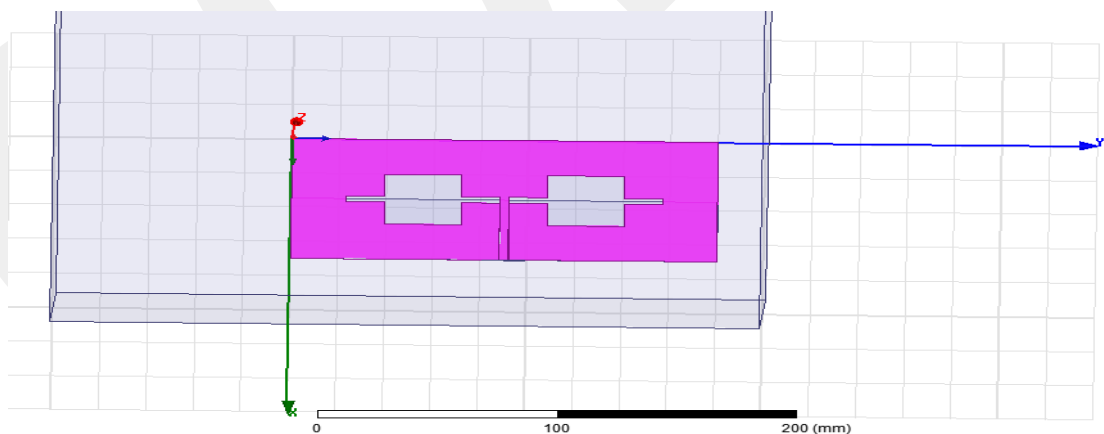

Figure 3.24. The proposed design multiband patch antenna with CPW-Fed at substrate thickness 1.6 mm.

In this structure, we have designed and simulated another microstrip patch antenna. The dimensions of microstrip patch antenna are $70 \times 180 \times 1.6 \text{ mm}^3$ and the same geometry dimensions are shown in the table 3.2 for slots.

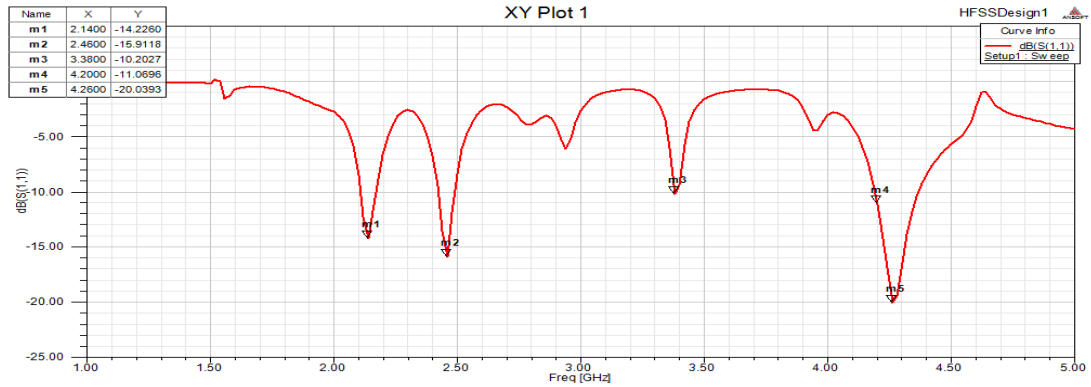

Figure 3.25. The return loss (S_{11}) of design has substrate thickness 1.6 mm.

In Figure 3.25, it is shown operating frequencies at the design in Figure 3.24. The results of return loss are -14dB, -15 dB, -10 dB, and -20 dB at frequencies 2.14 GHz, 2.46 GHz, 3.38 GHz, and 4.26 GHz in the order. This design operates multiband of frequencies.



Figure 3.26. The gain of design has substrate thickness 1.6 mm.

In Figure 3.26, it is shown the gain of the proposed design multiband patch antenna with CPW-Fed at substrate thickness 1.6 mm describes performance this antenna. In this design seems a good gain.

3.2.3.1 Design Microstrip Antenna with Slots in the Corners

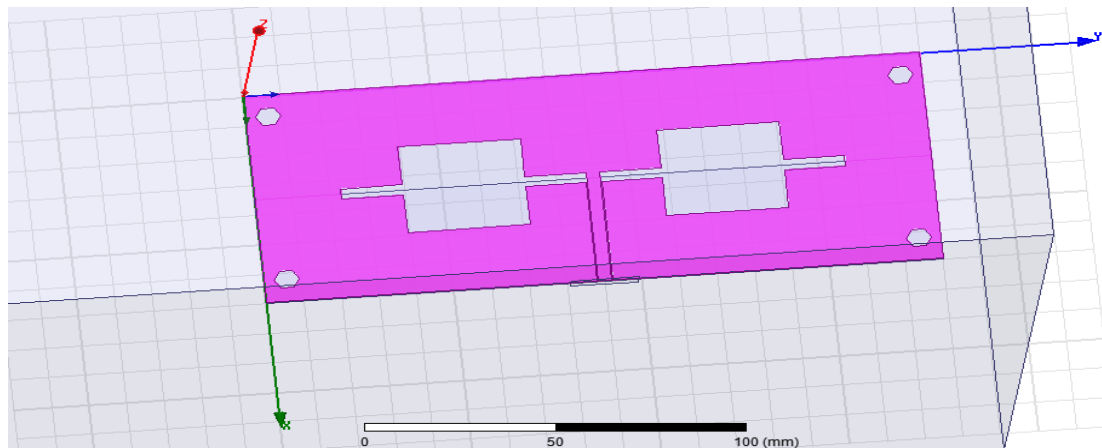

Figure 3.27. Design multiband patch antenna with CPW-Fed with four small hexagons in the corners.

In this structure, we designed and simulated a microstrip patch antenna with slots. The dimensions of microstrip patch antenna are $70 \times 180 \times 1.6 \text{ mm}^3$ and the same geometry dimensions are shown in the table 3.2 for slots. And we have designed antenna on 1.6 mm thickness FR4 substrate. Then, we have added four hexagons slots in the four corners. These hexagons dimension is $10/3 \text{ mm}$. This design will be manufactured and compared with results in simulation and measurement. It is shown that comparison in chapter four.

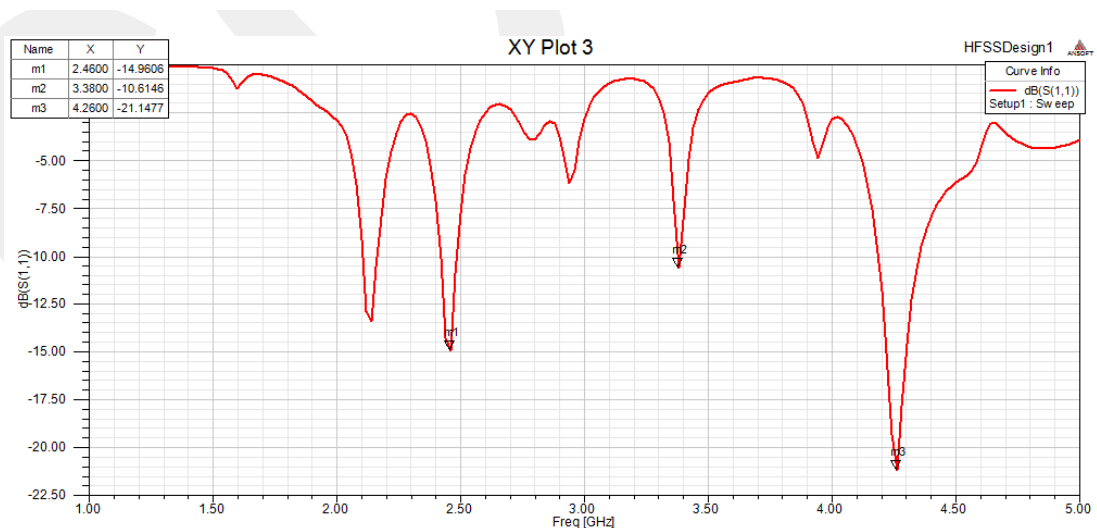

Figure 3.28. The return loss (S_{11}) of design multiband patch antenna with CPW-Fed with four small hexagons in the corners.

In Figure 3.28, it is shown operating frequencies at the design in Figure 3.27. The results of return loss are -14.9 dB, -10 dB, and -21 dB at frequencies 2.46 GHz, 3.38 GHz, and 4.2 GHz in the order. This design also operated multiband of frequencies.

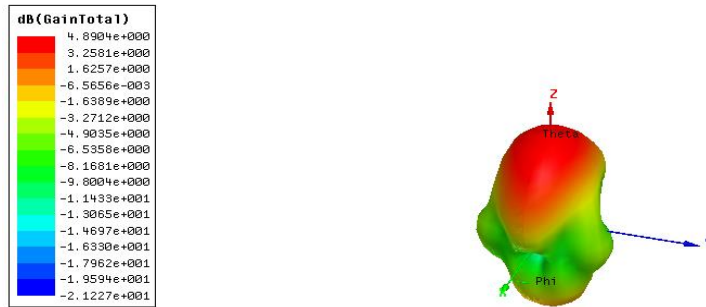

Figure 3.29. The gain of design multiband patch antenna with CPW-Fed with four small hexagons in the corners.

In Figure 3.29, it is shown the gain of the proposed design multiband patch antenna with CPW-Fed at substrate thickness 1.6 mm with four small hexagons in the corners describes performance this antenna. In this design seems a good gain.

Finally, we have changed the antenna design. The rectangles are replaced with hexagons shapes.

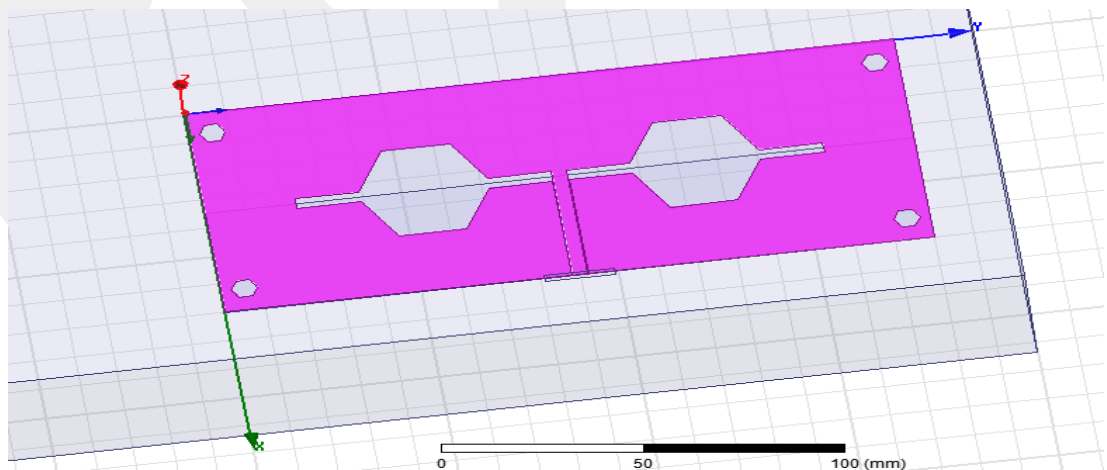

Figure 3.30. Design multiband patch antenna with CPW-Fed with a big hexagon instead a big rectangular and four small hexagons in the corners.

In this structure, the dimensions of microstrip patch antenna are $70 \times 180 \times 1.6 \text{ mm}^3$ and the same geometry dimensions are shown in the table 3.2 for slots. And we have designed antenna on 1.6 mm thickness FR4 substrate. Then, we added four hexagons slots in the four corners. These hexagons dimension is 10/3 mm. Then, we added two hexagons instead two rectangular. These hexagons dimensions are 17.3 mm. This structure will be manufactured and compared with results in simulation and measurement that is shown in chapter four.

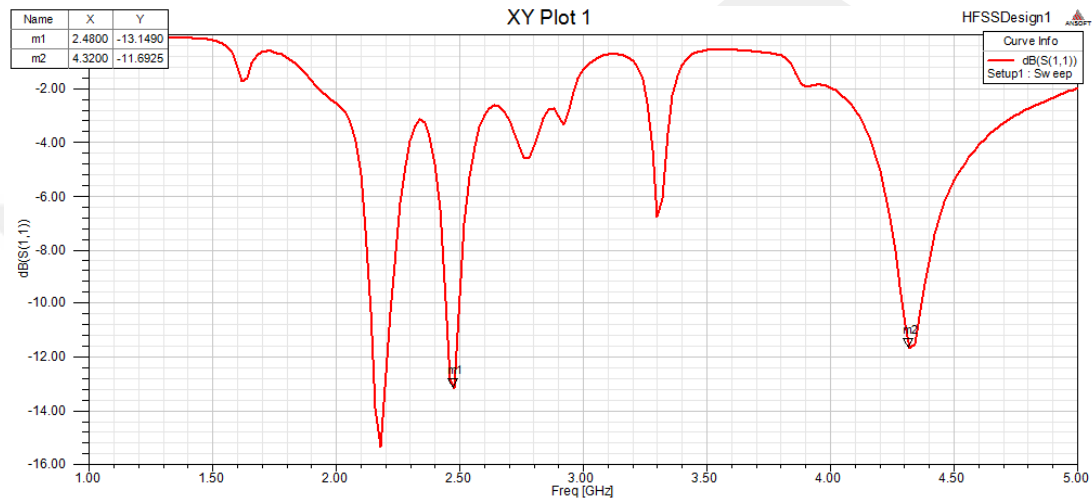

Figure 3.31. The return loss (S_{11}) of design multiband patch antenna with CPW-Fed with a big hexagon instead a big rectangular and four small hexagons in the corners.

In Figure 3.31, it is shown operating frequencies at the design in Figure 3.30. The results of return loss are -15 dB, -13 dB, and -11 dB at frequencies 2.18 GHz, 2.48 GHz, and 4.3 GHz in the order. This design also operated multiband of frequencies.

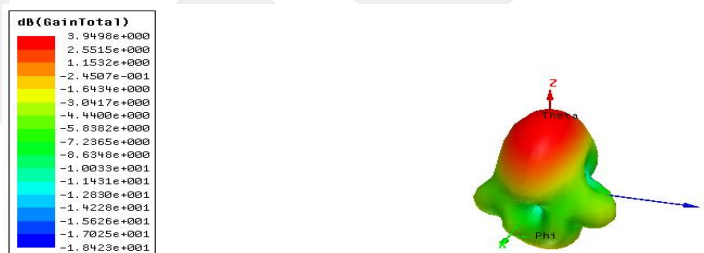

Figure 3.32. The gain of design multiband patch antenna with CPW-Fed with a big hexagon instead a big rectangular and four small hexagons in the corners.

In Figure 3.32 shown the gain of the proposed design multiband patch antenna with CPW-Fed at substrate thickness 1.6 mm with hexagons instead rectangular and four small hexagons in the corners describes performance this antenna. In this design seems a good gain.

Table 3-3. The results of designs with CPW feed.

Thickness of substrate	Design	Frequency resonance (GHz)	Return loss (dB)	Gain (dB)
1 mm	Figure 3.21	Lower frequency	-37	4.623
		2.46		
		Upper frequency	-14	
		4.28		
1.6 mm	Figure 3.24	Lower frequency	-14	4.8377
		2.14		
		Upper frequency	-20	
		4.26		
	Figure 3.27	Lower frequency	-14.9	4.89
		2.46		
		Upper frequency	-21	
		4.26		
	Figure 3.30	Lower frequency	-15	3.94
		2.2		
		Upper frequency	-11.6	
		4.3		

In the table 3.3 above, the results for simulation of designs are showing. We have seen all designs operated multiband frequencies. We have seen when we change the thickness of substrate from 1 mm to 1.6 mm the designs have seem agreement the frequencies with simple shift and small change in the gain.

3.3 DISCUSSION OF GAIN

Commonly antenna gain defined as “the ratio of the power generated by the antenna from a far-field source on the beam of antenna axis to the power generated by hypothetical lossless isotropic antenna, that is evenly sensitive to signals from all directions”. Generally this ratio is said to be in decibels. One of the disadvantages of the microstrip antennas is low gain because the gain affected by thickness of substrate and relative dielectric constant. This problem for low gain solved by using material with relative permittivity less than FR4_ epoxy. Antenna gain must be positive, in the first design the maximum gain is 4.7589 dB shown in table 3.1 above, and in the second design the maximum gain is 4.89 dB shown in table 3.3 above. The relationship between antenna gain and efficiency shown in the equation following.

$$G = \eta * D \quad (3.1)$$

Where G is antenna gain, η is antenna efficiency, and D is directivity [14].

CHAPTER FOUR

ANTENNA MANUFACTURING AND MEASUREMENT

4.1 INTRODUCTION

The manufacture of the antennas was done using the dimensions and substrate described in chapter three in simulation and result and discussion section. The patch antennas etched on FR4 epoxy, which have a dielectric constant is 4.4 and a thickness of substrate is 1.6 mm. We have been fabricated three structure are shown that in this chapter.

4.2 ANTENNA MANUFACTURING PROCESS

A manufacture is meant realization of design and simulation, and it sounds to be simple for the designer. It is necessary to be precise and more carefull a midst simulation and realization however the soft ware program is able to model and read any designs in the range of its library data. But, various error might be occur during the manufacture process.

4.2.1 Design Microstrip Patch Antenna with Five Quad Shapes

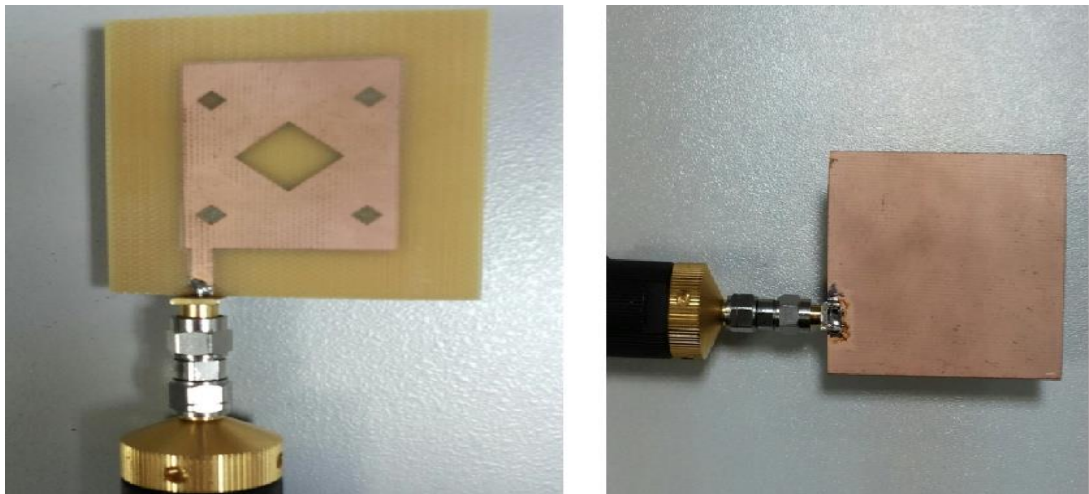

Figure 4.1. Two sides of antenna manufacture.

In Figure 4.1, it is shown the manufactured antenna. It is designed on the geometry in Figure 3.17. The dimension of substrate thickness is 1.6 mm FR4 – epoxy and it is made up of 50 Ω microstrip feeding line. The dimensions of the microstrip line are $3 \times 10 \text{ mm}^2$ and the dimensions of the patch are $38 \times 28 \text{ mm}^2$. Which it is ready to be measured by the vector analyzer.

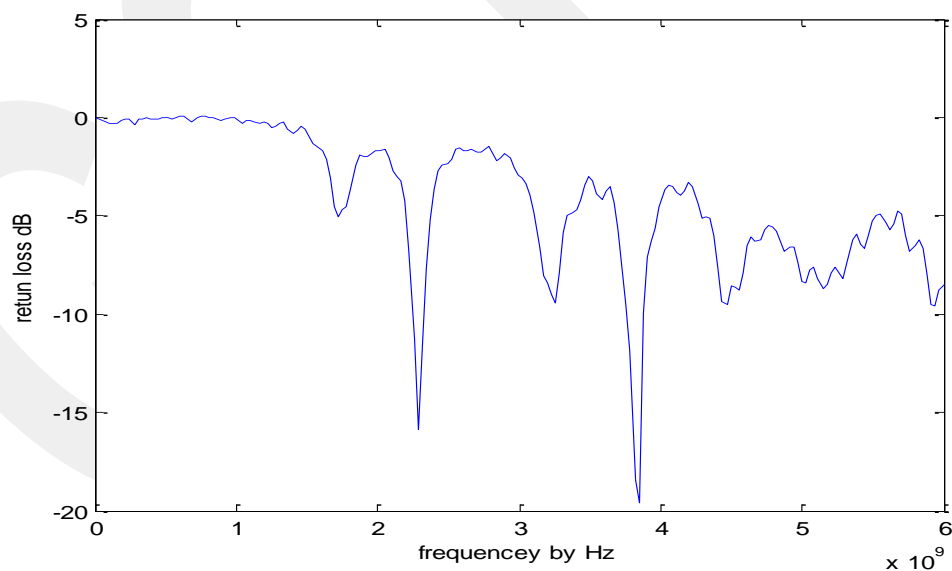

Figure 4.2. Measurement of the return loss (S_{11}).

Because transmission and reflection of electrical networks are simple to measure at high frequencies, network analyzers usually measure the return loss (S – parameters). Figure 4.2 is shown the return loss (S – parameter) measurement of vector analyzer. Then we are comparison between results in simulation and in measurement by the analyzer device.

Table 4-1. The difference for return loss between simulation and measurement.

Frequencies (GHz) in simulation	Return loss (dB) in simulation	Frequencies (GHz) in measurement	Return loss (dB) in measurement
2.27	-16	2.28	-10.9
3.78	-15.8	3.8	-15

In the table 4.1 above, it is shown comparison between results for design microstrip patch antenna with five quad shape in simulation and measurement. We have seen a good seem agreement between simulated and measured results.

4.2.2 Design Microstrip Patch Antenna with Four Hexagons Slots

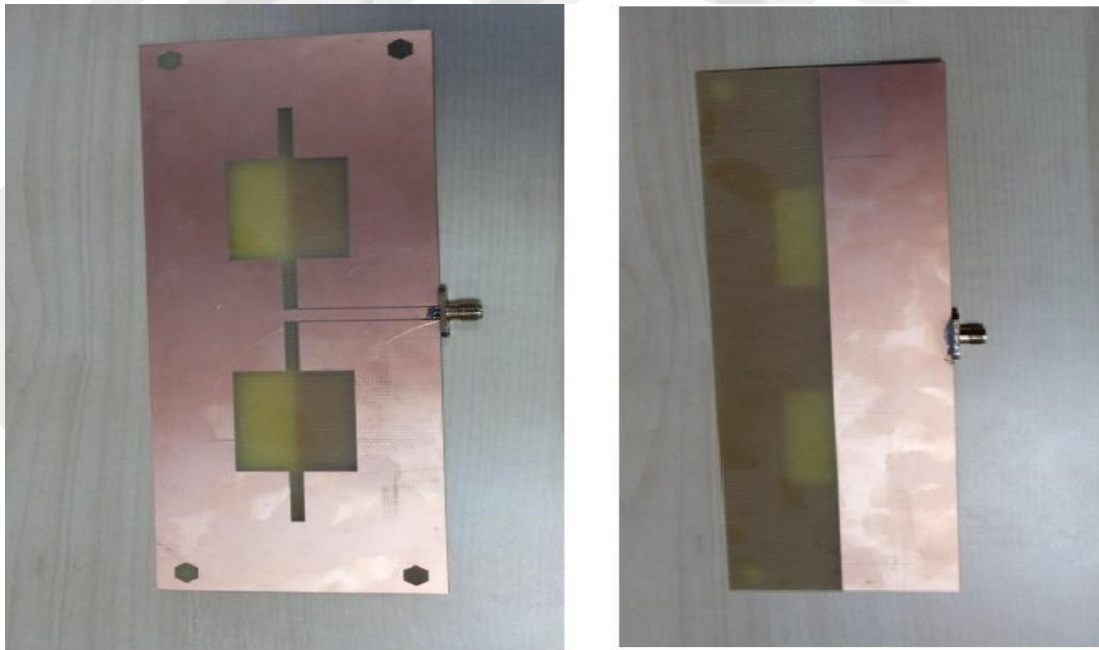

Figure 4.3. Two sides of antenna manufacture.

In Figure 4.3, it is shown the manufactured antenna. It is designed on the geometry in Figure 3.24. The dimension of substrate thickness is 1.6 mm FR4 – epoxy and it is made up of CPW feeding and we have added four small hexagons slots in the corners using the same dimension of the slot in Figure 3.8. The dimensions of the patch are $180 \times 70 \text{ mm}^2$. We have used to measure by the vector analyzer.

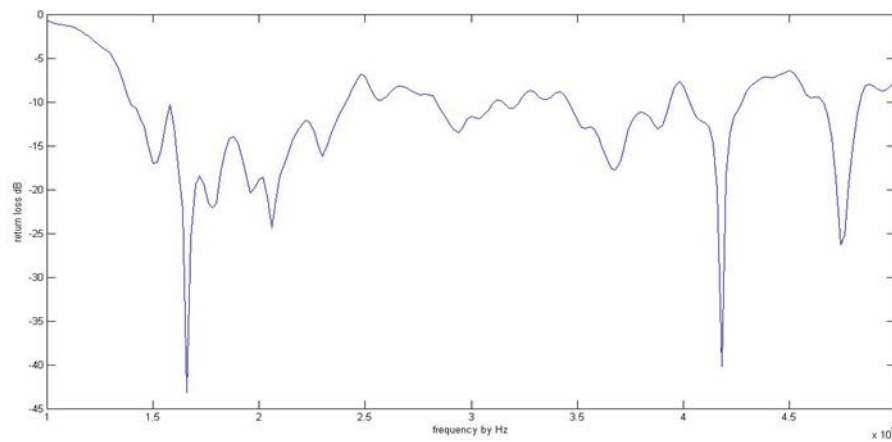

Figure 4.4. Measurement of the return loss (S_{11}).

Table 4-2. The difference for return loss between simulation and measurement.

Frequencies (GHz) in simulation	Return loss (dB) in simulation	Frequencies (GHz) in measurement	Return loss (dB) in measurement
2.17	-13	2.14	-15
2.46	-14.9	2.5	-11
3.38	-10	3.6	-14
4.26	-21	4.2	-20

In the table 4.2 above, it is shown comparison between results for design microstrip patch antenna at 1.6 mm thickness of substrate with four hexagons slots in the corners in simulation and measurement. We have seen a good seem agreement between simulated and measured results.

4.2.3 Design Microstrip Patch Antenna with Six Hexagons Slots

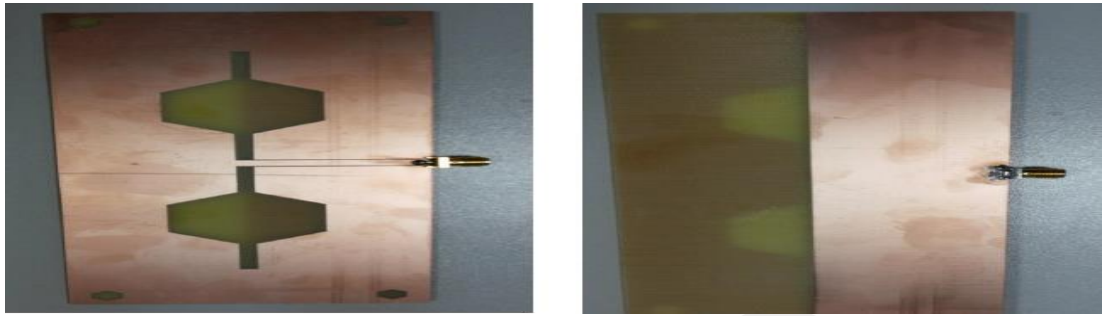

Figure 4.5. Two sides of antenna manufacture.

In Figure 4.5 is shown the manufactured antenna. It is designed on the same geometry in Figure 3.30. The dimension of substrate thickness is 1.6 mm FR4 – epoxy and it is made up of CPW feeding. The dimensions of the patch are 180×70 mm² and we have changed the shape of the slots in Figure 3.27 which two hexagons instead two rectangular and using the same geometry of the big rectangular. We have used to measure by the vector analyzer.

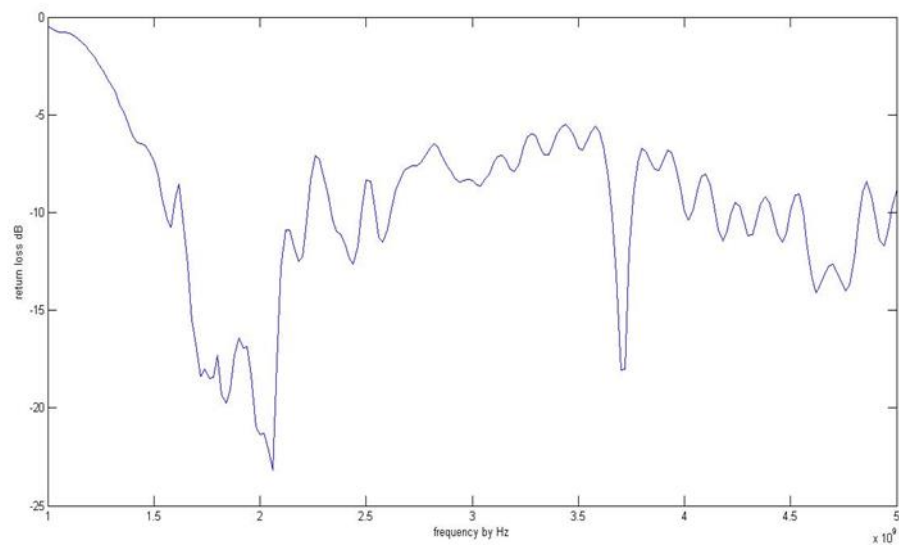

Figure 4.6. Measurement of the return loss (S_{11}).

In Figure 4.6, it is the return loss of the antenna measured by the vector analyzer and comparison between results in simulation and measurement. It is shown in table 4.3 following.

Table 4-3. The difference for return loss between simulation and measurrrement.

Frequencies (GHz) in simulation	Return loss (dB) in simulation	Frequencies (GHz) in measurement	Return loss (dB) in measurement
2.2	-15	2.19	-27
2.48	-13	2.5	-12
4.3	-11	4.4	-11

In the table 4.3 above, it is shown comparison between results for design microstrip patch antenna at 1.6 mm thickness of substrate with four hexagons slots in the corners and two hexagons instead two rectangular in the corners in simulation and measurement. We have seen a good seem agreement between simulated and measured results.

CHAPTER FIVE

CONCLUSION

In recent years, the research area of microstrip antennas has increased rapidly. Their applications are limitless, because of small size, light weight, and simple manufacturing. The aim of this work is designing an antenna for multiband operation for Wi-Fi devices and Wireless Communication System. These bands of frequency cover the standard IEEE 802.11b/g (2.4-2.485GHz) and IEEE 802.11a (5.15-5.35GHz) for WLAN (A wireless Local Area Network) applications and 2.5 GHz (2.5-2.69GHz), 3.5 GHz (3.3-3.8GHz) and 5 GHz (5.25-5.85GHz) for Wi-Max applications. We have designed the antenna to operate at multi-band frequency. Whereas the patch antenna designed at specific resonant frequency and it is operating at several frequencies. We designed multiband antenna using the soft ware program called HFSS (High Frequency Simulator Structure). After achievement the results for structures of the antennas that are sparingly close to the desirable radiation frequencies, the antennas were designed and tested.

Firstly, we have designed microstrip patch antenna using microstrip line feed must be able to fit operating multiband frequency for Wi-Fi device. We have used changing the shapes of slots to improve the gain. As we discussed results of simulation in chapter three. Then we chose one design, manufacture and test it. Then compare between the results in simulation and measurement. The results show a good agreement. As we discussed results of measurement in chapter four.

Secondly, we have designed microstrip patch antenna using coplanar waveguide feed must be able to fit operating multiband frequency for Wireless Communication System. We have designed the proposed antenna using the thickness of substrate 1 mm. Then we changed the thickness of substrate to 1.6 mm. We saw simple increase in bandwidth.

As we discussed results of simulation in chapter three. Then we chose two designs, manufacture and test them. Then compare between the results in simulation and measurement. In measurement result operated at the same frequencies in simulation but two antennas operated wide band in measurement from 1.5 GHz to 2.3 GHz.

In the tested for measurement, some variations of the results of simulation were observed on the operation of the actual antenna and are acceptable at almost all bands of operation. The results show great agreement between simulated and measured results.

Although those variation, the actual antennas are operated at frequencies, which shown in the table 4.1, table 4.2, and table 4.3 are employed in currently used in Wi-Fi devices and Wireless application.

In future work, we will reduce the size of microstrip patch antenna that will compatible with any kind of devices.

REFERENCES

- [1] C. A. Balanis, *Antenna Theory: Analysis and Design*. John Wiley & Sons, 2016.
- [2] S. Chen, Wang, Deng-Yin. And Tu Wen-Hua., "Dual-Band/Tri-Band/Broadband CPW-fed stepped-Impedance Slot Dipole Antennas," *IEEE Transactions on Antennas and Propagation.*, vol. 62, pp.485-490, 2014.
- [3] R. Garg, *Microstrip Antenna Design Handbook*. Artech house, 2001.
- [4] http://www.webopedia.com/TERM/M/multiband_antenna.html/ difention.
- [5] Q. Zhao, S. X. Gong, W. Jiang, B. Yang, and J. Xie. "Compact Wide-Slot Tri-Band Antenna for WLAN/WIMAX Applications," *Progress In Electromagnetics Research Letters.*, vol. 18, pp. 9-18, 2010.
- [6] H. Sabri and Z. Atlasbaf, "Two Novel Compact Triple-Band Microstrip Annular-Ring Slot Antenna for PCS-1900 and WLAN Applications," *Progress In Electromagnetics Research Letters.*, vol.5, pp. 87-98, 2008.
- [7] A. U. Bhoje, Holloway, Christopher L, Picket-May, Melinda and Hall, Richard, "Wide-Band Slot Antennas with CPW Feed Lines: Hybrid and Log-Periodic Designs," *IEEE Transactions on Antennas and Propagation.*, vol.52, pp.2545-2554, 2004.
- [8] L. Giauffret, Jean-Marc Laheurte, and A. Papiernik, "Study of Various Shapes of the Coupling Slot in CPW-Fed Microstrip Antennas," *IEEE Transactions on Antennas and Propagation.*, vol. 45, pp. 642-647, April. 1997.
- [9] S. Hu, Yiqiang Wu, Ye Zhang, and Huilin Zhou, "Design of a CPW-Fed Ultra Wide band Antenna," *Open Journal of Antenna and Propagation.*, vol. 1, pp. 18-22, 2013.

[10] G. Kumar and K. P. Ray. Broadband Microstrip Antennas. Artech House, 2003.

[11] P. Tendolkar, Arpan Shah, and Amutha Jeyakumar, "Study of CPW-Fed Slot Antenna for UWB Application," International Journal of Innovative Research in Computer and Communication Engineering., vol. 3, pp. 2826-2830, April. 2015.

[12] V. Bernard and John Paul Izuchukwu Iioh, "Microstrip Antenna Design Using Transmission Line Model," International Journal of Emerging Technology and Advanced Engineering., vol. 3, pp. 410-415, November. 2013.

[13] A. Elrashidi, Khaled Elleithy, and Hassan Bajwa, "Input Impedance, VSWR and Return Loss of a Conformal Microstrip Printed Antenna for TM_{01} Mode Using Two Different Substrates," International Journal of Networks and Communications., vol. 2, pp. 13-19, 2012.

[14] <https://en.wikipedia.org/wiki/Antenna>.

[15] S. Kumar Yadav, Kirti Vyas, Sudarshan Kumar, "A Hexagonal Shape Microstrip Patch Antenna for Wideband and Multiband Applications," International Journal of Scientific & Engineering Research., vol. 5, pp. 1469-1475, June. 2014.